

The accessories is necessary for intact air system. AirTAC has many types of accessories for your choice:

1. Polyurethane re-coil Hosepart;
2. Fitting;
3. Silencer;
4. Speed Controller.

Polyurethane tubing



- US98A, UE95A Series PU tubing.....
- UCS Series PU tubing.....
- PA12, PA6 Series nylon tubing.....
- UN54D Series flame resistant tubing.....

Fitting, Silencer



- One—Touch fittings: tube_thread type.....
- Metal one—Touch fittings.....
- One—Touch fittings: tube_tube type.....
- One—Touch fittings: threaded type.....
- Silencers.....

Speed Controller, Finger valve



- PSA, PSL, PSS Series Speed controllers.....
- PTL Series Push-lock Speed controllers.....
- PHV Series finger valve.....

Stainless steel fitting, Stainless steel silencer



- Stainless steel one—Touch fittings: tube_thread type.....
- Stainless steel one—Touch fittings: threaded type.....
- Stainless steel Silencers.....

Stainless steel speed Controller



- PSA, PSL, PSS Series Stainless steel Speed controllers...
- PTL Series Stainless steel Push-lock Speed controllers.....

Installation and Operation of tube and fitting

1. Installation and removal of tubing:

1.1. Installation of tubing

Grasp the tubing and slowly push it into the fitting until it comes to a stop. The tubing will be locked by the spring gasket.

1.2. Removal of tubing

Push the release button to open the spring gasket so that the tubing can be released.

Note: When remove the tubing, make sure the pressure in the tubing is Zero.

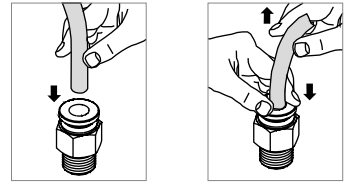

2. Connection thread tightening method

Use an inner or outer hexagon wrench to tighten the fitting as show in the picture below.

Note: Please refer to the tables below for the tightening torque and the depth of the thread screw-in.

Recommended tightening torque(N.m)					
Thread type	M5	1/8"	1/4"	3/8"	1/2"
Tightening torque	1~1.5	5~8	6~9	8~11	12~16

Depth of the thread screw-in (mm)			
Model\Item	Thread Length A	Depth of the thread A1	
M5	3	3	
1/8"	7.5	4	
1/4"	10	6	
3/8"	11	6.5	
1/2"	14	8	

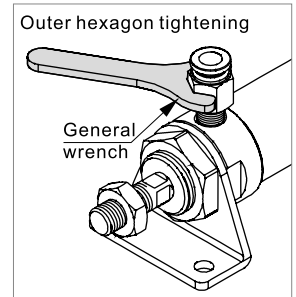
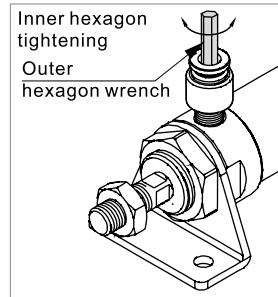

Note: If the fitting is connected with other parts, the external dimension L will be the value of the overall length of the fitting (B) minus the depth of the thread screw-in (A1).

3. Caution

3.1. External force (bend, twist, and tension) may damage the fitting and cause air leakage.

3.2. Insufficient installation may cause air leakage or the tubing to release.

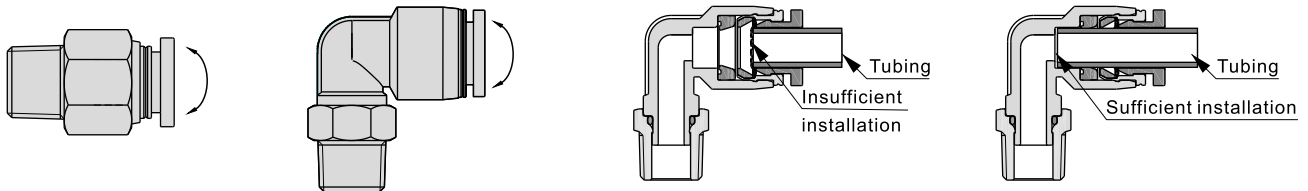

3.3. Pulling or twisting the tubing excessively may damage the fitting. For a mounting guide, see the table below.

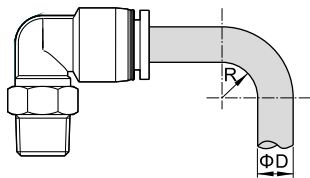

Minimum bending radius of the tubing(mm)					
Tubing O.D.(ΦD)	4	6	8	10	12
Minimum bending radius(R)	20	30	50	80	150

4. Connection thread tightening method of the fitting with M5 type thread

First, tighten by hand, then use a wrench to tighten an additional 1/4 turn. Excessive tightening may damage the thread portion or deform the gasket and cause air leakage. Insufficient tightening may loosen the threads, or cause air leakage.

5. Tolerance of the Polyurethane tubing O.D.

Polyurethane tubing O.D.(mm)	4	6	8	10	12
Tolerance(mm)	± 0.1	± 0.1	± 0.1	± 0.15	± 0.15



Other precautions

1. Before piping is connected, it should be washed to remove chips and other debris from inside the pipe.
2. Ensure the tubing being cut perpendicularly and no damage or scratch on the surface of the tubing outside diameter.
3. Use pipe length with sufficient margin to avoid over-bending on the top of the fitting.
4. Pull the tubing back gently to make sure it has a positive seal before using.
5. Push the release button flange evenly and sufficiently to release the button. If the release button is not held down sufficiently, the tubing cannot be with drawn and the outer surface of the tubing may be scratched and cause air leakage.
6. When removing tubing, do not rotate around or 360 degree. This may result in scratch and removal of the tubing difficult.
7. When screwing together pipes and fittings, be certain that chips from the pipe threads and sealing material do not get inside the pipe. Also, when the pipe tape is used, leave approx. 1.5~2 thread ridges exposed at the end of the threads.



Notes

Safety instructions

1. When remove the tubing, make sure the pressure in the tubing is Zero.
2. Do not use the ordinary fittings and tubing in locations where spatter is generated. Spattering may result in a fire hazard.
3. Ensure that the pressure and ambient temperature are within the specified range.
4. Do not use in an atmosphere having corrosive gases, chemicals, sea water, water, water steam, or where there is direct contact with any of these.
5. Do not use in a place subject to heavy vibration and/or shock.



Warning



Product feature

1. Plastic polyurethane material conforms to the ROHS environment protection requirement.
2. High elasticity: small bend radius enables PU tubing to pass through the tight space.
3. Anti-knot: better anti-knot effect than other plastic tubing.
4. Excellent flexibility: it can bear repeated expansion.
5. Anti-abrasion: long working life and suitable for the environment in which it is easy to be worn.
6. Low permeability of gas: relieve the problems of leakage and pollution.
7. Good anti-solubility: no solvent leaks, therefore it will not pollute the environment.
8. Low compression: maintain excellent physical character.
9. Wide resistance: it has certain resistance to chemicals, water, fuel, oil and bacterium.

Specification(Standard pressure type)

Type [Note1]	Tubing OD (mm)	Tubing ID (mm)	Wall Thickness (mm)	Package Length(m)	Working Pressure at 23°C(MPa)[Note2]	Burst pressure at 23°C(MPa)	Bend radius (mm)	Weight per 100M(kg)	Temperature (°C)
US98A032020□□	3.2	2.0	0.60	100/200	1.0	3.0	8	0.60	-20~70
US98A040025□□	4.0	2.5	0.75	100/200	1.0	3.0	10	0.94	
US98A060040□□	6.0	4.0	1.00	100/200	1.0	3.0	15	1.93	
US98A080050□□	8.0	5.0	1.50	100	1.0	3.0	20	3.66	
US98A100065□□	10.0	6.5	1.75	100	1.0	3.0	25	5.44	
US98A120080□□	12.0	8.0	2.00	100	1.0	3.0	35	7.56	
US98A160110□□	16.0	11.0	2.50	100	1.0	3.0	80	10.03	
UE95A032020□□	3.2	2.0	0.60	20/100/200	1.0	2.5	8	0.60	-40~70
UE95A040025□□	4.0	2.5	0.75	20/100/200	1.0	2.5	8	0.94	
UE95A060040□□	6.0	4.0	1.00	20/100/200	1.0	2.5	12	1.91	
UE95A080050□□	8.0	5.0	1.50	20/100	1.0	2.5	17	3.58	
UE95A100065□□	10.0	6.5	1.75	20/100	1.0	2.5	20	5.32	
UE95A120080□□	12.0	8.0	2.00	20/100	1.0	2.5	30	7.27	

[Note1] The first square of "□□" in the type column is for ordering code "unit" and the second is for "color".

[Note2] Working pressure:3 to 1 safety factor.

Specification(Lower pressure type)

Type [Note1]	Tubing OD (mm)	Tubing ID (mm)	Wall Thickness (mm)	Package Length(m)	Working Pressure at 23°C(MPa)[Note2]	Burst pressure at 23°C(MPa)	Bend radius (mm)	Weight per 100M(kg)	Temperature (°C)
US98A080055□□	8.0	5.5	1.25	100	0.8	2.0	20	3.25	-20~70
US98A080060□□	8.0	6.0	1.00	100	0.4	1.5	25	2.70	
US98A100080□□	10.0	8.0	1.00	100	0.4	1.5	40	3.47	
US98A120100□□	12.0	10.0	1.00	100	0.4	1.5	60	4.24	
US98A160120□□	16.0	12.0	2.00	100	0.4	2.0	80	8.32	
UE95A080055□□	8.0	5.5	1.25	20/100	0.8	1.5	17	3.18	-40~70

[Note1] The first square of "□□" in the type column is for ordering code "unit" and the second is for "color".

[Note2] Working pressure:3 to 1 safety factor.

Ordering code

US98A 060 040 100M BU

① ② ③ ④ ⑤

① Model	② Tubing OD	③ Tubing ID	④ Material length	⑤ Standard color [Note1]
US98A: Ester Base, Shore A98±2	032: Φ3.2mm	020: Φ2.0mm	100M: 100 m/coil 200M: 200 m/coil	BU: Blue BK: Black GE: Orange C: Clear WH: White CB: Clear Blue R: Red Y: Yellow GA: Gray GN: Green BR: Brown CR: Clear Red CG: Clear Green CY: Clear Yellow CE: Clear Orange
	040: Φ4.0mm	025: Φ2.5mm		
	060: Φ6.0mm	040: Φ4.0mm		
	080: Φ8.0mm	050: Φ5.0mm	100M: 100 m/coil	
	100: Φ10.0mm	055: Φ5.5mm		
	120: Φ12.0mm	060: Φ6.0mm		
160: Φ16.0mm				
UE95A: Ether Base, Shore A95±2	032: Φ3.2mm	020: Φ2.0mm	20M: 20 m/coil	
	040: Φ4.0mm	025: Φ2.5mm	100M: 100 m/coil	
	060: Φ6.0mm	040: Φ4.0mm	200M: 200 m/coil	
	080: Φ8.0mm	050: Φ5.0mm	20M: 20 m/coil	
	100: Φ10.0mm		100M: 100 m/coil	
	120: Φ12.0mm			

[Note1] Φ8xΦ6, Φ10xΦ8, Φ12xΦ10 type have nine standard colors: Blue\ Black\ Orange\ Clear\ White\ Clear Blue\ Red\ Yellow\ Gray.



Product feature

1. Plastic polyurethane material conforms to the ROHS environment protection requirement.
2. High elasticity: small bend radius enables PU tubing to pass through the tight space.
3. Anti-knot: better anti-knot effect than other plastic tubing.
4. Excellent flexibility: it can bear repeated expansion.
5. Anti-abrasion: long working life and suitable for the environment in which it is easy to be worn.
6. Low permeability of gas: relieve the problems of leakage and pollution.
7. Good anti-solubility: no solvent leaks, therefore it will not pollute the environment.
8. Low compression: maintain excellent physical character.
9. Wide resistance: it has certain resistance to chemicals, water, fuel, oil and bacterium.

Technical chart

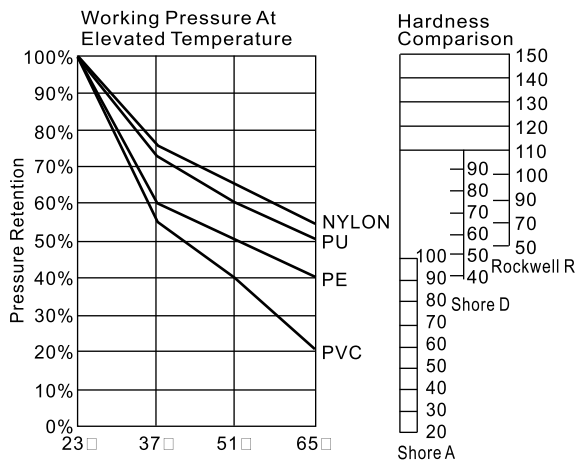

Specification (Standard pressure type)

Type [Note1]	Tubing OD(mm)	Tubing ID(mm)	Working Pressure at 23°C(MPa) [Note2]	Burst pressure at 23°C(MPa)	Bend radius(mm)	Length(m) [Note3]	Temp. (°C)
UCS060040□030□□	6.0	4.0	1.0	3.0	38	3	-20~70
UCS060040□060□□	6.0	4.0	1.0	3.0	38	6	
UCS060040□090□□	6.0	4.0	1.0	3.0	38	9	
UCS060040□120□□	6.0	4.0	1.0	3.0	38	12	
UCS060040□150□□	6.0	4.0	1.0	3.0	38	15	
UCS080050□060□□	8.0	5.0	1.0	3.0	38	6	
UCS080050□090□□	8.0	5.0	1.0	3.0	38	9	
UCS080050□120□□	8.0	5.0	1.0	3.0	38	12	
UCS080050□150□□	8.0	5.0	1.0	3.0	38	15	
UCS100065□060□□	10.0	6.5	1.0	3.0	50	6	
UCS100065□090□□	10.0	6.5	1.0	3.0	50	9	
UCS100065□120□□	10.0	6.5	1.0	3.0	50	12	
UCS100065□150□□	10.0	6.5	1.0	3.0	50	15	
UCS120080□060□□	12.0	8.0	1.0	3.0	60	6	
UCS120080□090□□	12.0	8.0	1.0	3.0	60	9	
UCS120080□120□□	12.0	8.0	1.0	3.0	60	12	
UCS120080□150□□	12.0	8.0	1.0	3.0	60	15	

Specification (Lower pressure type)

Type [Note1]	Tubing OD(mm)	Tubing ID(mm)	Working Pressure at 23°C(MPa) [Note2]	Burst pressure at 23°C(MPa)	Bend radius(mm)	Length(m) [Note3]	Temp. (°C)
UCS080055□060□□	8.0	5.5	0.8	2.0	38	6	-20~70
UCS080055□090□□	8.0	5.5	0.8	2.0	38	9	
UCS080055□120□□	8.0	5.5	0.8	2.0	38	12	
UCS080055□150□□	8.0	5.5	0.8	2.0	38	15	

[Note1] "□" in the type column is for "color", and "□□" is for "coupling type" and "coupling mode".

[Note2] Working pressure: 3 to 1 safety factor.

[Note3] Material length: length of operating status=(0.8~0.9)xMaterial length.

Ordering code

UCS 080 050 BU 090M A 1

① ② ③ ④ ⑤ ⑥ ⑦

① Model	② Tubing OD	③ Tubing ID	④ Standard color [Note1]	⑤ Material length	⑥ Coupling type	⑦ Coupling form
UCS: Ester Base	060: Φ6.0mm	040: Φ4.0mm	BU: Blue BK: Black GE: Orange C: Clear WH: White CB: Clear Blue R: Red Y: Yellow	030M: 3m 060M: 6m 090M: 9m 120M: 12m 150M: 15m	A: one end is 30cm and the other end is 10cm	1: Without coupling 2: With female-male coupling 3: With male-male coupling
	080: Φ8.0mm	050: Φ5.0mm			B: Both of the tubings of the couplings are 10cm	
	100: Φ10.0mm	055: Φ5.5mm			C: Both of the tubings of the couplings are 0cm	
	120: Φ12.0mm	065: Φ6.5mm	GN: Green BR: Brown CR: Clear Red CG: Clear Green CY: Clear Yellow CE: Clear Orange			
		080: Φ8.0mm				

[Note1] Lower pressure type has nine standard colors: Blue\ Black\ Orange\ Clear\ White\ Clear Blue\ Red\ Yellow\ Gray.

Pipe end coupling

Male quick coupling PP40 Φ12 × Φ8	Female quick coupling SP40 Φ12 × Φ8	Male quick coupling PP30 Φ10 × Φ6.5	Female quick coupling SP30 Φ10 × Φ6.5	Male quick coupling PP20 Φ8 × Φ5	Female quick coupling SP20 Φ8 × Φ5	Male quick coupling PP10 Φ6 × Φ4	Female quick coupling SP10 Φ6 × Φ4

PP40/SP40-PU tubing (12 × 8) quick coupling use PP30/SP30-PU tubing (10 × 6.5) quick coupling use PP20/SP20-PU tubing (8 × 5) quick coupling use PP10/SP10-PU tubing (6 × 4) quick coupling use



Product feature

1. PA12、PA6 Nylon tubing has excellence capability to be used high temperature conditions widely.
2. Many kinds of colors to be chosned.
3. Steady size, Little osmotic rate.
4. Be used widely for it's aging resistant, good anti-oil,and high temperature resistant capability.

Specification

Type [Note1]	Tubing OD (mm)	Tubing ID (mm)	Wall Thickness (mm)	Package Length(m)	Working Pressure at 23°C(MPa) [Note2]	Burst pressure at 23°C(MPa)	Bend radius (mm)	Weight per 100M(kg)	Temperature (°C)
PA6040025□□	4.0	2.5	0.75	200	3.5	11.0	30	0.90	-10~70
PA6060040□□	6.0	4.0	1.00	100	3.0	10.0	45	1.80	
PA6080060□□	8.0	6.0	1.00	100	2.0	7.0	65	2.50	
PA6100075□□	10.0	7.5	1.25	100	2.0	7.0	75	3.90	
PA6120090□□	12.0	9.0	1.50	100	2.0	7.0	100	5.70	
PA12040025□□	4.0	2.5	0.75	200	2.5	7.5	25	0.80	-40~70
PA12060040□□	6.0	4.0	1.00	100	2.0	7.0	35	1.60	
PA12080060□□	8.0	6.0	1.00	100	1.5	5.0	55	2.30	
PA12100075□□	10.0	7.5	1.25	100	1.5	5.0	75	3.50	
PA12120090□□	12.0	9.0	1.50	100	1.5	5.0	75	5.10	

[Note1] The first square of "□□" in the type column is for ordering code "unit" and the second is for "color".

[Note2] Working pressure:3 to 1 safety factor.

Relationship of operation pressure and temperature

Temperature	PA6 the percentage of work pressure reached at different temperatures					PA12 the percentage of work pressure reached at different temperatures				
	20°C	40°C	60°C	80°C	100°C	20°C	30°C	50°C	60°C	80°C
Percentage	100%	74%	57%	47%	40%	100%	83%	75%	64%	47%

Ordering code

Pa12 060 040 100M BU				
① Model	② Tubing OD	③ Tubing ID	④ Material length	⑤ Standard color
PA6: Nylon 6 PA12: Nylon 12	040: Φ4.0mm 060: Φ6.0mm 080: Φ8.0mm 100: Φ10.0mm 120: Φ12.0mm	025: Φ2.5mm 040: Φ4.0mm 060: Φ6.0mm 075: Φ7.5mm 090: Φ9.0mm	200M: 200 m/coil(4X2.5) 100M: 100 m/coil(Others)	BU : Blue BK : Black GE : Orange N : Clear WH : White GN : Green R : Red Y : Yellow

Product feature

1. Monolayer tubing with flame resistant.
2. Excel in elasticity: can pass compactness space with lesser bend radius.
3. Excellent water-resistant and flexibility.
4. Super doughty wearable and higher intensity of stretch.



Specification

Type [Note1]	Tubing OD (mm)	Tubing ID (mm)	Wall Thickness (mm)	Package Length(m)	Working Pressure at 23°C (MPa)	Burst pressure at 23°C	Bend radius (mm)	Weight per 100M(kg)	Temperature (°C)
UN54D□060040□□	6.0	4.0	1.00	100	1.0	4.0	12	1.93	-20~70
UN54D□080050□□	8.0	5.0	1.50	100	1.0	4.0	18	3.66	
UN54D□100065□□	10.0	6.5	1.75	100	1.0	4.0	20	5.44	
UN54D□120080□□	12.0	8.0	2.00	100	1.0	4.0	20	7.56	

[Note1] "□□" in the type column is for "color"

Ordering code

UN54D 120 080 100M Y



① Model	② Tubing OD	③ Tubing ID	④ Material length	⑤ Standard color
UN54D: Flame resistant tubing54D±3	060: Φ6.0mm 080: Φ8.0mm 100: Φ10.0mm 120: Φ12.0mm	040: Φ4.0mm 050: Φ5.0mm 065: Φ6.5mm 080: Φ8.0mm	100M: 100 m/coil	BU: Blue BK: Black GN: Green WH: White R: Red Y: Yellow

Relationship of operation pressure and temperature

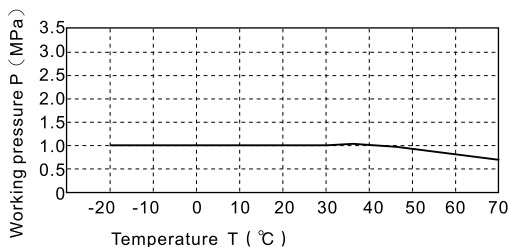

Mini bend radius

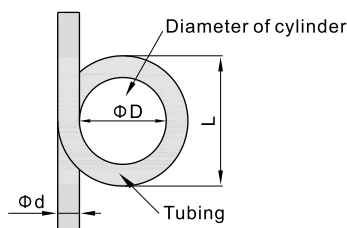

The least bend radius (JIS method)

JIS method (Base on JIS B8381 standard)

When the tubing circle the cylinder tightly and the distortion rate is 25%, the cylinder radius is the least bend radius.

Testing condition: 20°C, 65%RH

$$N = \{1 - (L - D) / 2d\} \times 100$$

N=Distortion rate (%), less than 25% of standard value.

d=Tubing diameter (mm)



L=Measure value (mm)

D=Diameter of cylinder (mm)

Ordering code

PC 6 01 □ □

① ② ③ ④ ⑤

① Model	② Port size	③ Thread connection		④ Standard color		⑤ Thread type
PC: Male connector 	4: Φ 4mm 6: Φ 6mm 8: Φ 8mm	Thread connection	Adaptable port size	Standard color	Specification	Blank: PT
POC: Male connector 	10: Φ 10mm 12: Φ 12mm	M5: M5X0.8	Φ 4, Φ 6	Blank: Gray	Release button: Gray	
		01: 1/8"	Φ 4, Φ 6	D: Black	Release button: Black	
		02: 1/4"	Φ 8, Φ 10			
		03: 3/8"	Φ 12			
		04: 1/2"				

Specification

Operating pressure range	0~10kgf/cm ² (0~1.0MPa)
Negative pressure	-750mmHg(10Torr)
Proof pressure	1.5MPa
Ambient and fluid temperature (°C)	-20~70
Applicable tubing	Soft nylon or polyurethane
Color	Grey/black

Table for interface port and tube O.D.

Product series	Thread type	Port size				
		Φ 4	Φ 6	Φ 8	Φ 10	Φ 12
PC	M5	●	●			
	1/8"	●	●	●	●	●
	1/4"	●	●	●	●	●
	3/8"		●	●	●	●
	1/2"		●	●	●	●
POC	M5	●	●			
	1/8"	●	●	●	●	
	1/4"	●	●	●	●	●
	3/8"		●	●	●	●
	1/2"		●	●	●	●

Product feature

1. The compact appearance space saving.

2. The threaded portion is covered with sealant and the M5 thread is attached with a sealing gasket to prevent air leakage over the connection thread portion.

3. Grey and black are optional for the release button.

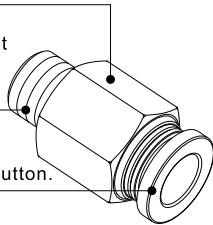

Inner structure

PC Series

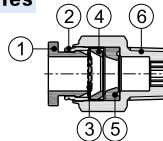

No.	Item	Material
1	Release button	POM
2	Guide	Aluminum alloy
3	Spring gasket	Stainless steel
4	Chuck	POM
5	O-ring	NBR
6	Body	Brass

Dimensions

PC Series

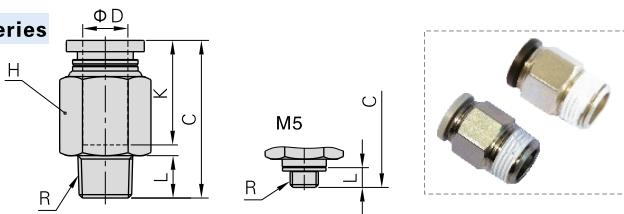

POC Series

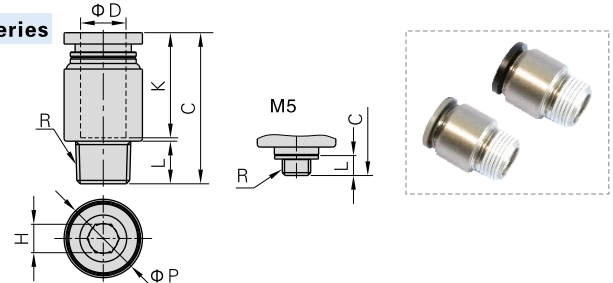



Model\Item	Φ D	R	L	C	K	H(Across flat)	Weight(g)
PC4M5	4	M5×0.8	3.5	19.5	14	9	6.5
PC401		1/8"	7.5	19.5	14	10	7
PC402		1/4"	10	19.5	14	14	13.5
PC6M5	6	M5×0.8	3.5	22.5	16.5	12	8.5
PC601		1/8"	7.5	22.0	18.5	12	7.5
PC602		1/4"	10	24.5	18.5	14	15.5
PC603		3/8"	11	22.5	18.5	17	24
PC604		1/2"	14	26.0	18.5	21	46
PC801	8	1/8"	7.5	28	18.5	14	13.5
PC802		1/4"	10	27	18.5	14	13
PC803		3/8"	11	23.5	18.5	17	21
PC804		1/2"	14	27	18.5	21	43.5
PC1001	10	1/8"	7.5	30	21	17	20.5
PC1002		1/4"	10	32.5	21	17	24
PC1003		3/8"	11	28	21	17	20.5
PC1004	12	1/2"	14	26.5	21	21	36
PC1201		1/8"	7.5	32.5	23	21	38.5
PC1202		1/4"	10	35	23	21	40.5
PC1203		3/8"	11	30.5	23	21	28.5
PC1204	1/2"	14	32.5	23	21	41.5	

Model\Item	Φ D	R	Φ P	L	C	K	H(Across flat)	Weight(g)	
POC4M5	4	M5×0.8	9	3.5	18.5	14	2.5	3.6	
POC401		1/8"	10	7.5	18	14	3	5.5	
POC402		1/4"	14	10	19.5	14	3	12.6	
POC6M5	6	M5×0.8	12	3.5	21.5	16.5	2	5.9	
POC601		1/8"	12	7.5	22.0	18.5	4	6.3	
POC602		1/4"	14	10	22.0	18.5	4	11.8	
POC801		8	1/8"	14	7.5	26.5	18	5	9.9
POC802			1/4"	14	10	25	18	6	10.1
POC803	3/8"		17	11	23.5	18	6	19.3	
POC1001	10	1/8"	17	7.5	30	21	5	16.5	
POC1002		1/4"	17	10	29	21	6	15.4	
POC1003		3/8"	17	11	28	21	8	18.7	
POC1004	12	1/2"	21	14	26.5	21	8	35.3	
POC1202		1/4"	21	10	34.5	23	6	32.3	
POC1203		3/8"	21	11	30	23	8	25.1	
POC1204		1/2"	21	14	32	23	8	37.5	

Ordering code

PC 6 01 □ □ - M

1 2 3 4 5 6

① Model	② Port size	③ Thread connection	④ Standard color		⑤ Thread type	⑥ Style type	
PC: Male connector 	3.2: Φ 3.2mm 4: Φ 4mm 6: Φ 6mm	Thread connection: Adaptable port size	Standard color	Specification	Blank: PT	M: Mini type	
PL: Male elbow 		M3: M3X0.5	Φ 3.2, Φ 4	Blank: Gray			Release button: Gray
		M5: M5X0.8	Φ 3.2, Φ 4, Φ 6	D: Black			Release button: Black
		01: 1/8"	Φ 4, Φ 6				

Specification

Operating pressure range	0~10kgf/cm ² (0~1.0MPa)
Negative pressure	-750mmHg(10Torr)
Proof pressure	1.5MPa
Ambient and fluid temperature (°C)	-20~70
Applicable tubing	Soft nylon or polyurethane
Color	Grey/black

Table for interface port and tube O.D.

Product series	Thread type	Port size		
		Φ 3.2	Φ 4	Φ 6
PC/PL	M3	●	●	
	M5	●	●	●
	1/8"		●	●

Product feature

1. The compact appearance space saving.
2. The threaded portion is covered with sealant and the M3/M5 thread is attached with a sealing gasket to prevent air leakage over the connection thread portion.
3. Grey and black are optional for the release button.

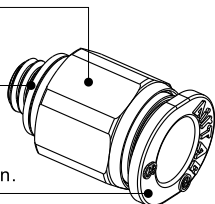

Dimensions

PC Series

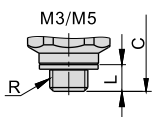
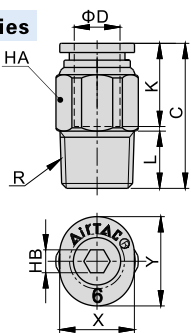

PL Series

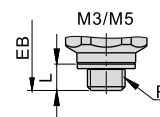
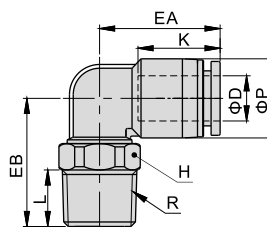
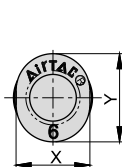

Model/Item	ΦD	R	L	C	K	X	Y	HA	HB	Weight(g)
PC3.2M3-M	3.2	M3×0.5	3	16	11.5	6.8	8.7	7	1.5	1.7
PC3.2M5-M		M5×0.8	3.5	16	11.5	6.8	8.7	7	2	2.0
PC4M3-M	4	M3×0.5	3	17.5	12.5	7.8	9.5	8	1.5	2.4
PC4M5-M		M5×0.8	3.5	17	12.5	7.8	9.5	8	2	2.7
PC401-M	6	1/8"	7.5	17.5	13.5	7.8	9.5	10	3	5.5
PC6M5-M		M5X0.8	3.5	18.5	13.5	9.8	11.7	10	2	3.6
PC601-M	1/8"	7.5	19.0	15.5	9.8	11.7	10	4	6.0	













Model/Item	ΦD	R	ΦP	L	K	EA	EB	H	X	Y	Weight(g)
PL3.2M3-M	3.2	M3×0.5	7.5	3	12	14.5	14	7	6.8	8.7	2.4
PL3.2M5-M		M5×0.8		3.5	12		14.5	7	6.8	8.7	2.7
PL4M3-M	4	M3×0.5	8.5	3	12.5	15	14	7	7.8	9.5	3.0
PL4M5-M		M5×0.8		3.5	12.5		14.5	7	7.8	9.5	3.3
PL401-M	6	1/8"	10.5	7.5	12.5	16.0	16	10	7.8	9.5	6.2
PL6M5-M		M5X0.8		3.5	13.5		15.5	7	9.8	11.7	4.0
PL601-M	1/8"	7.5	13.5	7.5	13.5	16.5	10	9.8	11.7	6.8	

Ordering code

Same diameter type fittings

PL 6 01

1 2 3 4 5

① Model	② Port size	③ Thread connection	④ Standard color	⑤ Thread type	
PHW: Double universal male elbow 	PL: Male elbow 	Thread connection	Standard color	Blank: PT	
PHF: Universal female elbow 	PLL: Extended male elbow 	M5: M5X0.8	Adaptable port size Φ4, Φ6		Specification Release button: Gray Adaptable model PCF PMF
PEB: Male branch tee 	PLF: Female elbow 				Blank: Gray Release button: Gray Body: Gray Others
PED: Male run tee 	PCF: Female connector 	01: 1/8" 02: 1/4" 03: 3/8" 04: 1/2"	D: Black		Release button: Black PCF PMF
PYB: Branch "Y" 	PMF: Bulkhead connector 				Release button: Black Body: Black Others
PZB: Threaded cross 	PH: Universal male elbow 				

Different diameter type fittings

PKD 6 - 4 01

1 2 3 4 5 6

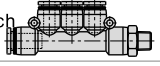
① Model	② Port size	③ Port size	④ Thread connection	⑤ Standard color	⑥ Thread type
PKD: Male reducer triple branch 	6: Φ6mm 8: Φ8mm 10: Φ10mm	4: Φ4mm 6: Φ6mm 8: Φ8mm	01: 1/8" 02: 1/4" 03: 3/8"	Standard color: Blank: Gray Specification: Release button: Gray/Body: Gray D: Black Release button: Black/Body: Black	Blank: PT

Specification

Operating pressure range	0~10kgf/cm ² (0~1.0MPa)
Negative pressure	-750mmHg(10Torr)
Proof pressure	1.5MPa
Ambient and fluid temperature (°C)	-20~70
Applicable tubing	Soft nylon or polyurethane
Color	Grey/black

Product feature

- Variable models can be widely used in every kind of pneumatic systems.
- High circulation performance: bear the same flow with the volume of the tubing inside diameter.
- Connect tubing easily and conveniently. The tubing connection portion is safe and durable.
- The threaded portion is covered with sealant and the M5 thread is attached with a sealing gasket to prevent air leakage over the connection thread portion.
- The nickel plated body is anti-corrosion and anti-pollution, which allows a broader application.

Inner structure

No.	Item	Material
1	Release button	POM
2	Guide	Aluminum alloy
3	Spring gasket	Stainless steel
4	Chuck	POM
5	O-ring	NBR
6	Body	PBT
7	O-ring	NBR
8	Stud	Brass

Table for interface port and tube O.D.

Product series	Thread type	Port size				
		Φ4	Φ6	Φ8	Φ10	Φ12
PL	M5	●	●			
	1/8"	●	●	●	●	●
	1/4"	●	●	●	●	●
	3/8"		●	●	●	●
PLL	1/2"		●	●	●	●
	M5	●	●			
	1/8"	●	●	●	●	
	1/4"	●	●	●	●	●
PEB	3/8"		●	●	●	●
	1/2"		●	●	●	●
	M5	●	●			
	1/8"	●	●	●	●	
PED	1/4"	●	●	●	●	●
	3/8"		●	●	●	●
	1/2"		●	●	●	●
	M5	●	●			
PH	1/8"	●	●			
	1/4"	●	●	●	●	
	3/8"		●	●	●	●
	1/2"		●	●	●	●
PHF	1/8"	●	●	●	●	
	1/4"		●	●	●	●
	3/8"		●	●	●	●
	1/2"		●	●	●	●
PHW	1/8"	●	●	●	●	
	1/4"		●	●	●	●
	3/8"		●	●	●	●
	1/2"		●	●	●	●
PZB	1/8"		●	●		
	1/4"		●	●	●	
	3/8"		●	●	●	●
	1/2"		●	●	●	●

Product series	Thread type	Port size		
		Φ6-Φ4	Φ8-Φ6	Φ10-Φ8
PKD	1/8"	●		
	1/4"		●	
	3/8"			●

Dimensions

PL Series

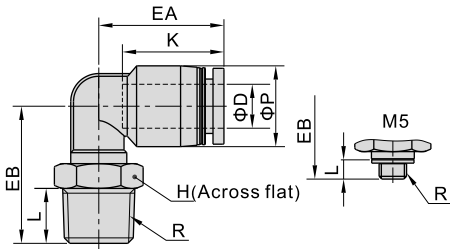

PCF Series

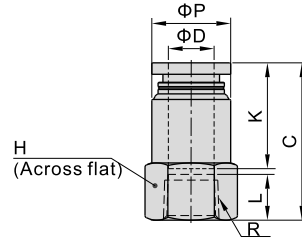

Model\Item	ΦD	R	ΦP	L	K	EA	EB	H	Weight(g)
PL4M5	4	M5×0.8	9	3.5	14	17	15	8	3
PL401		1/8"	9	7.5	14	17	18.5	10	4.5
PL402		1/4"	9	10	14	17	22.0	14	12
PL6M5	6	M5×0.8	12.5	3.5	17	20	17.0	8	4.5
PL601		1/8"	12.5	7.5	17	20	20.5	10	6
PL602		1/4"	12.5	10	17	20	24.0	14	13.5
PL603		3/8"	12.5	11	17	20	25.5	17	20.5
PL604	1/2"	12.5	14	17	20	30.0	21	36	
PL801	8	1/8"	15	7.5	18.5	23	20.5	10	7.5
PL802		1/4"	15	10	18.5	23	25.0	14	13
PL803		3/8"	15	11	18.5	23	26.5	17	21
PL804		1/2"	15	14	18.5	23	31.0	21	36
PL1001	10	1/8"	18	7.5	21	25.5	25.0	17	16.5
PL1002		1/4"	18	10	21	25.5	27.0	17	19
PL1003		3/8"	18	11	21	25.5	28.0	17	21
PL1004		1/2"	18	14	21	25.5	32.5	21	37
PL1201	12	1/8"	21	7.5	23	28.5	26.5	17	19
PL1202		1/4"	21	10	23	28.5	28.5	17	21.5
PL1203		3/8"	21	11	23	29.5	33	17	25.5
PL1204		1/2"	21	14	23	29.5	34	21	37

Model\Item	ΦD	R	ΦP	L	C	K	H	Weight(g)
PCF4M5	4	M5×0.8	9	5	21	14	10	2.7
PCF401		1/8"	9.5	8	23	14	14	4.5
PCF402		1/4"	9.5	11	26	14	17	6.5
PCF6M5	6	M5×0.8	12	5	21.5	16.5	12	3.9
PCF601		1/8"	12.5	8	25.5	16.5	14	5.6
PCF602		1/4"	12.5	11	28.5	16.5	17	7.5
PCF603		3/8"	13	12	29.5	16.5	21	10.7
PCF604	1/2"	13	13.5	31.0	16.5	25	13.8	
PCF801	8	1/8"	14	8	27.5	18.5	14	5.8
PCF802		1/4"	14.5	11	30.5	18.5	17	8.4
PCF803		3/8"	14.5	12	31.5	18.5	21	11.2
PCF804		1/2"	14.5	13.5	33	18.5	25	14.4
PCF1001	10	1/8"	17	8	29	21	17	9.5
PCF1002		1/4"	17	11	33	21	17	9.9
PCF1003		3/8"	18	12	34	21	21	14
PCF1004		1/2"	18	13.5	35.5	21	25	17.1
PCF1202	12	1/4"	21	11	33.5	23	21	17.5
PCF1203		3/8"	21	12	35.5	23	21	16.6
PCF1204		1/2"	21	13.5	37	23	25	19.7

PMF Series

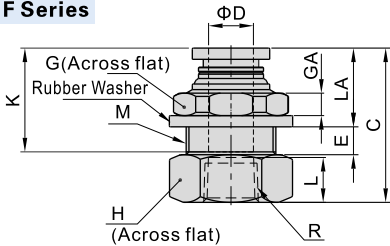

PLF Series

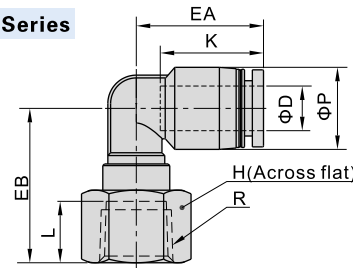

Model\Item	ΦD	R	M	L	C	K	LA	E	GA	G	H	Weight(g)
PMF401	4	1/8"	M12X1	8	25	14	12	4	4	14	14	6.4
PMF402		1/4"	M12X1	11	29	14	12	4	4	14	17	9
PMF601		1/8"	M14X1	8	25.5	16.5	12.5	5	4	17	17	9.1
PMF602	6	1/4"	M14X1	11	30.5	16.5	12.5	5	4	17	17	10.9
PMF603		3/8"	M14X1	12	31.5	16.5	12.5	5	4	17	21	13.2
PMF801		1/8"	M16X1	8	27.5	18.5	13.5	5.5	4	19	19	12.8
PMF802		1/4"	M16X1	11	32	18.5	13.5	5.5	4	19	19	15.7
PMF803	8	3/8"	M16X1	12	33	18.5	13.5	5.5	4	19	21	15
PMF804		1/2"	M16X1	13.5	34.5	18.5	13.5	5.5	4	19	25	18.1
PMF1001		1/8"	M20X1	8	30	21	14.5	7.5	5	24	22	19.6
PMF1002		1/4"	M20X1	11	35	21	14.5	7.5	5	24	22	22.8
PMF1003	10	3/8"	M20X1	12	36	21	14.5	7.5	5	24	22	21.1
PMF1004		1/2"	M20X1	13.5	37.5	21	14.5	7.5	5	24	25	23.2
PMF1202		1/4"	M22X1	11	34.5	23	15.5	8	6	27	24	26.2
PMF1203		12	3/8"	M22X1	12	37.5	23	15.5	8	6	27	24
PMF1204	1/2"		M22X1	13.5	39	23	15.5	8	6	27	25	26.2

Model\Item	ΦD	R	ΦP	L	K	EA	EB	H	Weight(g)
PLF4M5	4	M5×0.8	9	5	14	17	16	10	2.9
PLF401		1/8"	9	8	14	17	21	14	4.6
PLF402		1/4"	9	11	14	17	24	17	6.8
PLF6M5	6	M5×0.8	12.5	5	17	20	18.5	10	7
PLF601		1/8"	12.5	8	17	20	23	14	5.8
PLF602		1/4"	12.5	11	17	20	26	17	8
PLF603		3/8"	12.5	12	17	20	27	21	10.7
PLF801	8	1/8"	15	8	18.5	23	20	14	6.6
PLF802		1/4"	15	11	18.5	23	27.5	17	9.2
PLF803		3/8"	15	12	18.5	23	28.5	21	11.9
PLF804		1/2"	15	13.5	18.5	23	30	25	15.2
PLF1001	10	1/8"	18	8	21	25.5	24	17	11.3
PLF1002		1/4"	18	11	21	25.5	26.5	17	11.2
PLF1003		3/8"	18	12	21	25.5	30	21	14.5
PLF1004		1/2"	18	13.5	21	25.5	31.5	25	17.4
PLF1202	12	1/4"	21	11	23	28.5	28.5	17	13.7
PLF1203		3/8"	21	12	23	29.5	32	21	17.4
PLF1204		1/2"	21	13.5	23	29.5	33	25	20.4

PLL Series

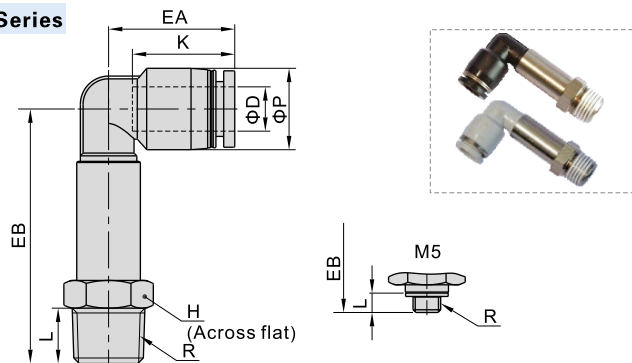

Model\Item	ΦD	R	ΦP	L	K	EA	EB	H	Weight(g)
PLL4M5	4	M5×0.8	9	3.5	14	17	32.5	8	8.9
PLL401		1/8"	9	7.5	14	17	35.5	10	12.3
PLL402		1/4"	9	10	14	17	38.5	14	16.9
PLL6M5	6	M5×0.8	12.5	3.5	17	20	34.5	8	9.9
PLL601		1/8"	12.5	7.5	17	20	37.5	10	13
PLL602		1/4"	12.5	10	17	20	40.5	14	18
PLL603	8	3/8"	12.5	11	17	20	43	17	23.4
PLL801		1/8"	15	7.5	18.5	23	43.5	12	16.6
PLL802		1/4"	15	10	18.5	23	45.5	14	22.7
PLL803	10	3/8"	15	11	18.5	23	48	17	27.7
PLL1001		1/8"	18	7.5	21	25.5	50.5	15	37.5
PLL1002		1/4"	18	10	21	25.5	53.5	15	40.6
PLL1003	12	3/8"	18	11	21	25.5	54.5	17	40.7
PLL1004		1/2"	18	14	21	25.5	59	21	47.4
PLL1202		1/4"	21	10	23	28.5	55.5	15	43
PLL1203	12	3/8"	21	11	23	29.5	60	17	55.4
PLL1204		1/2"	21	14	23	29.5	63	21	56.7

PHW Series

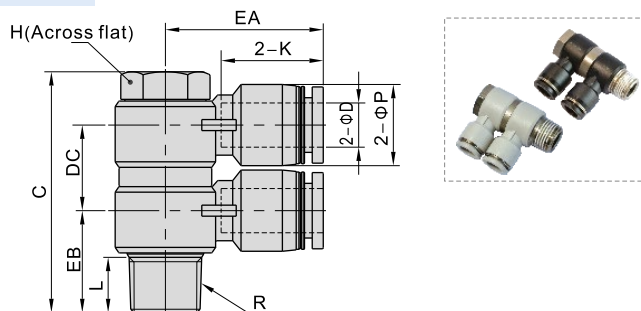

Model\Item	ΦD	R	ΦP	L	C	K	EA	EB	DC	H	Weight(g)
PHW401	4	1/8"	9	7.5	38	14	20.5	14.5	13	11	19
PHW601		1/8"	12.5	7.5	38	16.5	23.0	15	13	11	21
PHW602	6	1/4"	12.5	10	43.5	16.5	25.0	17.5	15.5	14	40.2
PHW603		3/8"	12.5	11	50	16.5	27.0	20	16.5	19	69.2
PHW801	8	1/8"	15	7.5	40.5	18.5	26.5	16.5	15.5	11	23.6
PHW802		1/4"	15	10	43.5	18.5	28.5	18.5	15.5	14	40.8
PHW803		3/8"	15	11	50	18.5	29.5	20	16.5	19	70.4
PHW804	10	1/2"	15	14	61	18.5	32	24.5	22	24	134.8
PHW1002		1/4"	18	10	46.5	21	31	20	18.5	14	47
PHW1003		3/8"	18	11	55	21	33	21	22	19	87.5
PHW1004	12	1/2"	18	14	61	21	35.5	25	22	24	137.7
PHW1203		3/8"	21	11	55	23	36	23	22	19	86.4
PHW1204	12	1/2"	21	14	61	23	38	26.5	22	24	147.5

PH Series

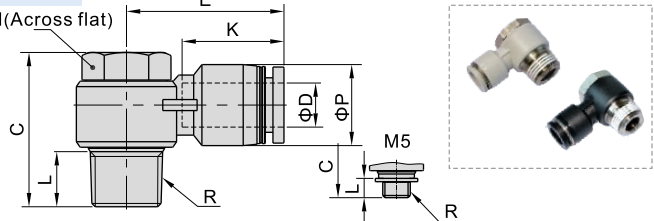

Model\Item	ΦD	R	ΦP	L	C	K	E	H	Weight(g)
PH4M5	4	M5×0.8	9	3.5	17	14	19	8	5.8
PH401		1/8"	9	7.5	25	14	20.5	11	12.8
PH6M5	6	M5×0.8	12.5	3.5	17	16.5	23.5	8	6.8
PH601		1/8"	12.5	7.5	25	16.5	23	11	14
PH602	8	1/4"	12.5	10	28	16.5	25	14	25.4
PH603		3/8"	12.5	11	33	16.5	27	19	50.2
PH801		1/8"	15	7.5	25	18.5	26.5	11	14.7
PH802	10	1/4"	15	10	28	18.5	28.5	14	26.4
PH803		3/8"	15	11	33	18.5	29.5	19	49.4
PH804	12	1/2"	15	14	39	18.5	32	24	89
PH1002		1/4"	18	10	28	21	31	14	27.7
PH1003	10	3/8"	18	11	33	21	33	19	51.1
PH1004		1/2"	18	14	39	21	35.5	24	88.5
PH1203	12	3/8"	21	11	33	23	36	19	53
PH1204		1/2"	21	14	39	23	38	24	92.8

PHF Series

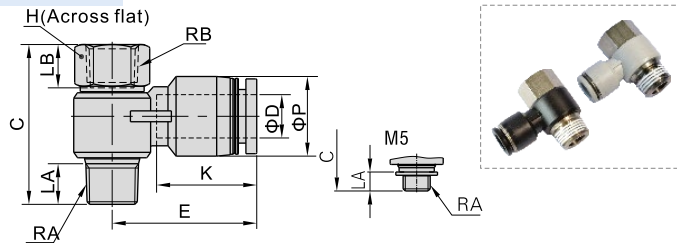

Model\Item	ΦD	RA	RB	ΦP	LA	LB	C	K	E	H	Weight(g)
PHF4M5	4	M5×0.8	M5×0.8	9	3.5	6	20	14	19	8	6.2
PHF401		1/8"	1/8"	9	7.5	8	29.5	14	20.5	12	12.9
PHF6M5	6	M5×0.8	M5×0.8	12.5	3.5	6	20	16.5	23.5	8	7.1
PHF601		1/8"	1/8"	12.5	7.5	8	29.5	16.5	23	12	13.9
PHF602	8	1/4"	1/4"	12.5	10	11	35	16.5	25	17	30.3
PHF603		3/8"	3/8"	12.5	11	12	40	16.5	27	19	44.2
PHF801		1/8"	1/8"	15	7.5	8	29.5	18.5	26.5	12	15
PHF802	10	1/4"	1/4"	15	10	11	35	18.5	28.5	17	30.7
PHF803		3/8"	3/8"	15	11	12	40	18.5	29.5	19	44.8
PHF804	12	1/2"	1/2"	15	14	13.5	47.5	18.5	32	24	84.7
PHF1002		1/4"	1/4"	18	10	11	35	21	31	17	32
PHF1003	10	3/8"	3/8"	18	11	12	40	21	33	19	46.2
PHF1004		1/2"	1/2"	18	14	13.5	47.5	21	35.5	24	86.1
PHF1203	12	3/8"	3/8"	21	11	12	40	23	36	19	48.4
PHF1204		1/2"	1/2"	21	14	13.5	47.5	23	38	24	89.7

PKD Series

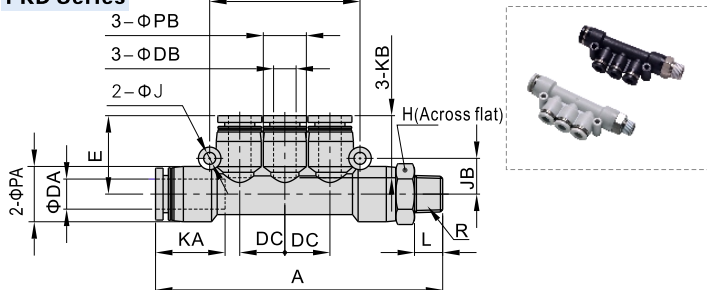

Model\Item	ΦDA	ΦDB	R	L	A	ΦPA	ΦPB	KA
PKD6-401	6	4	1/8"	7.5	66.5	12.5	9	16.5
PKD8-602	8	6	1/4"	10	79	15	12.5	18.5
PKD10-803	10	8	3/8"	11	91.5	18	15	21

Model\Item	KB	ΦJ	JB	JC	DC	E	H	Weight(g)
PKD6-401	14	3.2	8	34	10	17.5	12	15.8
PKD8-602	16.5	3.2	9.5	40	12	21	14	26.5
PKD10-803	18.5	4.3	11	48	14.5	24	17	38.2

PEB Series

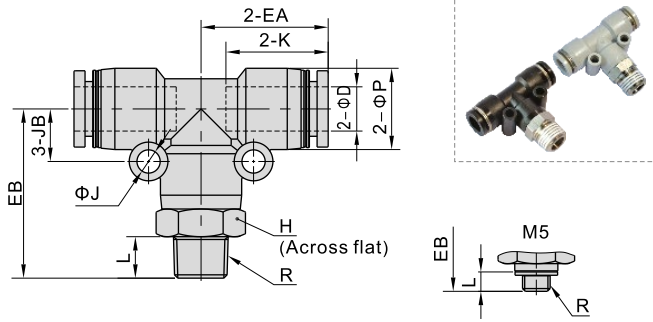

Model\Item	φD	R	φP	L	K	EA	EB	φJ	JB	H	Weight(g)
PEB4M5		M5x0.8	9	3.5	14	17	21	3.2	6.5	9	6.8
PEB401	4	1/8"	9	7.5	14	17	25	3.2	6.5	10	8.8
PEB402	4	1/4"	9	10	14	17	28	3.2	6.5	14	15.5
PEB6M5		M5x0.8	12.5	3.5	16.5	20	23.5	3.2	8	12	11.2
PEB601	6	1/8"	12.5	7.5	16.5	20	27.5	3.2	8	12	13.5
PEB602	6	1/4"	12.5	10	16.5	20	30.5	3.2	8	14	18.6
PEB603	6	3/8"	12.5	11	16.5	20	32	3.2	8	17	25.3
PEB801	8	1/8"	15	7.5	18.5	23	30.5	4.3	9.5	14	18.4
PEB802	8	1/4"	15	10	18.5	23	33	4.3	9.5	14	21.3
PEB803	8	3/8"	15	11	18.5	23	34.5	4.3	9.5	17	28.2
PEB804	8	1/2"	15	14	18.5	23	38.5	4.3	9.5	21	41
PEB1001	10	1/8"	18	7.5	21	26.5	34	4.3	11	17	26.7
PEB1002	10	1/4"	18	10	21	26.5	36.5	4.3	11	17	29.2
PEB1003	10	3/8"	18	11	21	26.5	37.5	4.3	11	17	31.9
PEB1004	10	1/2"	18	14	21	26.5	41.5	4.3	11	21	45.4
PEB1202	12	1/4"	21	10	23	30	41	4.3	13	21	49.6
PEB1203	12	3/8"	21	11	23	30	42	4.3	13	21	51.2
PEB1204	12	1/2"	21	14	23	30	45	4.3	13	21	57.3

PYB Series

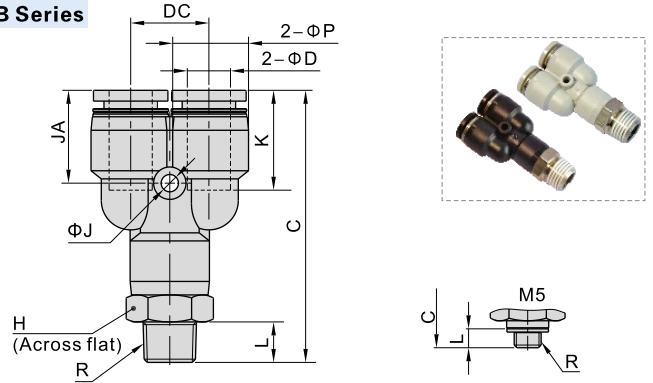

Model\Item	φD	R	φP	L	C	K	φJ	JA	DC	H	Weight(g)
PYB4M5		M5x0.8	9	3.5	35.5	14	3.2	13	10	9	6.7
PYB401	4	1/8"	9	7.5	39.5	14	3.2	13	10	10	9
PYB402	4	1/4"	9	10	42.5	14	3.2	13	10	14	10.8
PYB6M5		M5x0.8	12.5	3.5	40.5	16.5	3.2	15.5	12	12	11.1
PYB601	6	1/8"	12.5	7.5	44.5	16.5	3.2	15.5	12	12	13.7
PYB602	6	1/4"	12.5	10	47.5	16.5	3.2	15.5	12	14	18.2
PYB603	6	3/8"	12.5	11	49.0	16.5	3.2	15.5	12	17	25
PYB801	8	1/8"	15	7.5	50	18.5	3.2	17	14.5	14	19.8
PYB802	8	1/4"	15	10	52.5	18.5	3.2	17	14.5	14	22
PYB803	8	3/8"	15	11	54	18.5	3.2	17	14.5	17	27.7
PYB804	8	1/2"	15	14	58	18.5	3.2	17	14.5	21	40.8
PYB1001	10	1/8"	18	7.5	56.5	21	4.3	19.5	18	17	27.4
PYB1002	10	1/4"	18	10	59	21	4.3	19.5	18	17	29.5
PYB1003	10	3/8"	18	11	60	21	4.3	19.5	18	17	32.5
PYB1004	10	1/2"	18	14	64	21	4.3	19.5	18	21	45.4
PYB1202	12	1/4"	21	10	66	23	4.3	21	20.5	21	27.3
PYB1203	12	3/8"	21	11	67	23	4.3	21	20.5	21	51.8
PYB1204	12	1/2"	21	14	70	23	4.3	21	20.5	21	56.8

PED Series

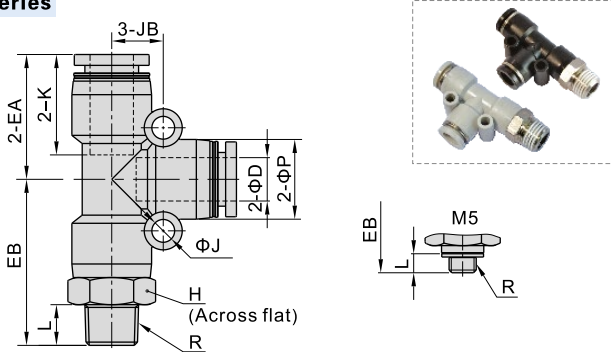

Model\Item	φD	R	φP	L	K	EA	EB	φJ	JB	H	Weight(g)
PED4M5		M5x0.8	9	3.5	14	17	21	3.2	6.5	9	6.8
PED401	4	1/8"	9	7.5	14	17	25	3.2	6.5	10	8.8
PED402	4	1/4"	9	10	14	17	28	3.2	6.5	14	15.5
PED6M5		M5x0.8	12.5	3.5	16.5	20	23.5	3.2	8	12	11.2
PED601	6	1/8"	12.5	7.5	16.5	20	27.5	3.2	8	12	13.5
PED602	6	1/4"	12.5	10	16.5	20	30.5	3.2	8	14	18.6
PED603	6	3/8"	12.5	11	16.5	20	32	3.2	8	17	25.3
PED801	8	1/8"	15	7.5	18.5	23	30.5	4.3	9.5	14	18.4
PED802	8	1/4"	15	10	18.5	23	33	4.3	9.5	14	21.3
PED803	8	3/8"	15	11	18.5	23	34.5	4.3	9.5	17	28.2
PED804	8	1/2"	15	14	18.5	23	38.5	4.3	9.5	21	41
PED1001	10	1/8"	18	7.5	21	26.5	34	4.3	11	17	26.7
PED1002	10	1/4"	18	10	21	26.5	36.5	4.3	11	17	29.2
PED1003	10	3/8"	18	11	21	26.5	37.5	4.3	11	17	31.9
PED1004	10	1/2"	18	14	21	26.5	41.5	4.3	11	21	45.4
PED1202	12	1/4"	21	10	23	30	41	4.3	13	21	49.6
PED1203	12	3/8"	21	11	23	30	42	4.3	13	21	51.2
PED1204	12	1/2"	21	14	23	30	45	4.3	13	21	57.3

PZB Series

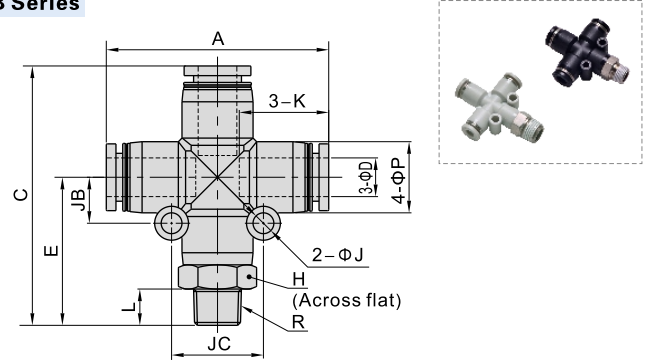

Model\Item	φD	R	L	A	E	C	φP	K	φJ	JB	JC	H	Weight(g)
PZB601	6	1/8"	7.5		27.5	47.5						12	15.2
PZB602	6	1/4"	10	39.5	30.5	50.5	12.5	16.5	3.2	8	16	14	20.4
PZB603	6	3/8"	11		32	52						17	27
PZB801	8	1/8"	7.5		30.5	53.5						14	20.9
PZB802	8	1/4"	10	46	33	56	15	18.5	4.3	9.5	19	14	23.8
PZB803	8	3/8"	11		34.5	57.5						17	29.9
PZB804	8	1/2"	14		38.5	61.5						21	43.5
PZB1002	10	1/4"	10		36.5	63						17	33.5
PZB1003	10	3/8"	11	52.5	37.5	64	18	21	4.3	11	22	17	36.5
PZB1004	10	1/2"	14		41.5	68						21	49.2
PZB1203	12	3/8"	11		42	72						21	56.5
PZB1204	12	1/2"	14	59.5	45	75	21	23	4.3	13	26	21	65.4

Ordering code

BPC 6 01 □

① ② ③ ④

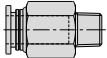
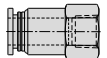
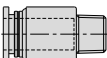
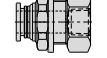
① Model		② Port size	③ Thread connection	④ Thread type
BPC: Metal male connector 	BPCF: Metal female connector 	4: Φ 4mm 6: Φ 6mm 8: Φ 8mm 10: Φ 10mm 12: Φ 12mm	M5: M5X0.8 01: 1/8" 02: 1/4" 03: 3/8" 04: 1/2"	Blank: PT
BPOC: Hexagon socket head metal male connector 	BPMF: Metal bulkhead female connector 			

BPM 6

① ②

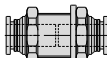
① Model	② Port size
BPM: Metal bulkhead connector 	4: Φ 4mm 6: Φ 6mm 8: Φ 8mm 10: Φ 10mm 12: Φ 12mm

Specification

Operating pressure range	0~9kgf/cm²(0~0.9MPa)
Negative pressure	-750mmHg(10Torr)
Proof pressure	1.5MPa
Ambient and fluid temperature (°C)	0~150
Applicable tubing	Soft nylon or polyurethane
Color	Grey/black

Note: The temperature resistance level of the tubing should be confirmed first when used in high temperature environments.

Product feature

- High flow capacity; The flow rate of these fittings is equivalent to that of the adaptable tubings.
- Inserting or removal tubing is simple and convenient, and the connecting portion is reliable and durable.
- Sealant is coated on threaded portion. The M5 metric thread is attached with a sealing gasket, to ensure no leakage of the threaded connection part.
- The fitting metal body adopts a special nickel-plating process, which has good corrosion resistance.
- Metal fittings can be used in high temperature environment.

Table for interface port and tube O.D.

Product series	Thread type	Port size				
		Φ4	Φ6	Φ8	Φ10	Φ12
BPC	M5	●	●			
	1/8"	●	●	●	●	
	1/4"	●	●	●	●	●
	3/8"		●	●	●	●
	1/2"				●	●
BPOC BPCF	M5	●	●			
	1/8"	●	●	●		
	1/4"		●	●	●	
	3/8"				●	●
	1/2"					●
BPMF	M5					
	1/8"	●	●	●		
	1/4"		●	●	●	
	3/8"				●	●
	1/2"					●
Product series	Port size					
BPM	Φ4	Φ6	Φ8	Φ10	Φ12	
	●	●	●	●	●	

Inner structure

BPC Series

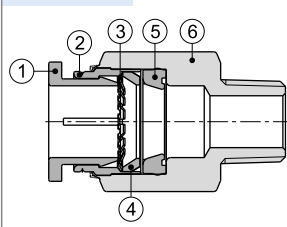

NO.	Name	Material
1	Metal connector	Brass
2	Locating ring	Aluminum alloy
3	Spring gasket	Stainless steel
4	Locating seat	Aluminum alloy
5	Special shape O-ring	Viton
6	Straight connector body	Brass

Dimensions

BPC Series

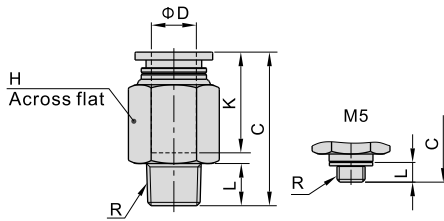

Model/Item	ΦD	R	L	C	K	H	Weight(g)
BPC4M5	4	M5X0.8	3.5	19.5	14	9	5.5
BPC401		1/8"	7.5	19.5	14	10	7.9
BPC402		1/4"	10	19	14	14	8.7
BPC6M5	6	M5X0.8	3.5	22	16	12	10.1
BPC601		1/8"	7.5	21.5	18	12	14.2
BPC602		1/4"	10	24	18	14	19.1
BPC603	3/8"	11	22.5	18	17	26.8	
BPC801	8	1/8"	7.5	27.5	18	14	16.1
BPC802		1/4"	10	26.5	18	14	16
BPC803		3/8"	11	23	18	17	25.4
BPC1001	10	1/8"	7.5	29.5	20.5	17	24.5
BPC1002		1/4"	10	32	20.5	17	28
BPC1003		3/8"	11	27.5	20.5	17	34.6
BPC1004	1/2"	14	25.5	20.5	21	39.3	
BPC1202	12	1/4"	10	34.5	22	21	44.5
BPC1203		3/8"	11	30	22	21	34.2
BPC1204		1/2"	14	32	22	21	47

BPOC Series

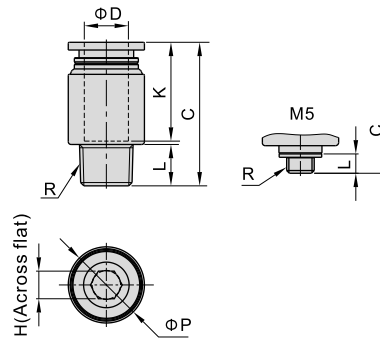

Model/Item	ΦD	R	ΦP	L	C	K	H	Weight(g)
BPOC4M5	4	M5X0.8	9	3.5	18.5	14	2	4.4
BPOC401		1/8"	10	7.5	17.5	14	2.5	6.6
BPOC6M5	6	M5X0.8	12	3.5	21	16	2	7.1
BPOC601		1/8"	12	7.5	21.5	18	4	8.4
BPOC602		1/4"	14	10	21.5	18	4	13.6
BPOC801	8	1/8"	14	7.5	26	17.5	5	12.3
BPOC802		1/4"	14	10	24.5	17.5	6	12.7
BPOC1002	10	1/4"	17	10	28.5	20.5	6	18.5
BPOC1003		3/8"	17	11	27.5	20.5	8	24.9
BPOC1203	12	3/8"	21	11	29.5	22	8	30.4
BPOC1204		1/2"	21	14	31.5	22	8	42.4

BPCF Series

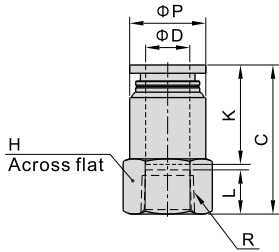

Model/Item	ΦD	R	ΦP	L	C	K	H	Weight(g)
BPCF4M5	4	M5X0.8	9	5	21	14	10	3.5
BPCF401		1/8"	9.5	8	23	14	14	5.3
BPCF6M5	6	M5X0.8	12	5	21	16	12	5.6
BPCF601		1/8"	12.5	8	25	16	14	7.2
BPCF602		1/4"	12.5	11	28	16	17	9.2
BPCF801	8	1/8"	14	8	27	18	14	7.1
BPCF802		1/4"	14.5	11	30	18	17	10.6
BPCF1002	10	1/4"	17	11	32.5	20.5	17	13.5
BPCF1003		3/8"	18	12	33.5	20.5	21	17.5
BPCF1203	12	3/8"	21	12	35	22	21	22
BPCF1204		1/2"	21	13.5	36.5	22	25	24.9

BPMF Series

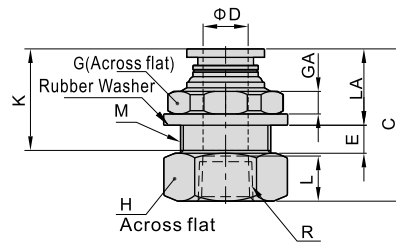

Model/Item	ΦD	R	M	L	C	K	LA	E	GA	G	H	Weight(g)
BPMF401	4	1/8"	M12X1	8	25	14	12	4	4	14	14	7.6
BPMF601	6	1/8"	M14X1	8	25	16	12	5	4	17	17	10.4
BPMF602		1/4"	M14X1	11	30	16	12	5	4	17	17	12.2
BPMF801	8	1/8"	M16X1	8	27	18	13	5.5	4	19	19	13.9
BPMF802		1/4"	M16X1	11	31.5	18	13	5.5	4	19	19	15.3
BPMF1002	10	1/4"	M20X1	11	34.5	20.5	14	7.5	5	24	22	26.2
BPMF1003		3/8"	M20X1	12	35.5	20.5	14	7.5	5	24	22	24.4
BPMF1203	12	3/8"	M22X1	12	37	22	15	8	6	27	24	32.6
BPMF1204		1/2"	M22X1	13.5	38.5	22	15	8	6	27	25	31.8

BPM Series

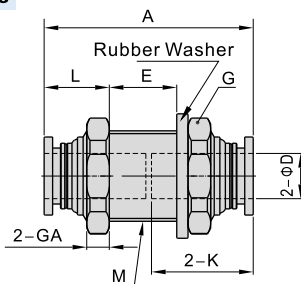







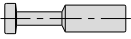

Model/Item	ΦD	M	A	K	L	E	G(Across flat)	GA	Weight(g)
BPM4	4	M12X1	28.5	14	10	7	14	4	6.4
BPM6	6	M14X1	33	16	10	11	17	4	16.4
BPM8	8	M16X1	37	18	11	13	19	4	15.8
BPM10	10	M20X1	41.5	20.5	12	16	24	5	28.9
BPM12	12	M22X1	45	22	13	17.5	27	6	40.3

Ordering code









Same diameter type fittings

PE 6 □
① ② ③

① Model				② Port size	③ Standard color		
PM: Bulkhead union 	PE: Union tee 	PP: Plug 	PV: Union elbow 	4: Φ4mm 6: Φ6mm 8: Φ8mm 10: Φ10mm 12: Φ12mm	Standard color	Specification	Adaptable model
PLM: Bulkhead male elbow 	PY: Union "Y" 	PZ: Cross 	PU: Straight union 		Blank: Gray	Release button: Gray Body: Gray	PM Others
					D: Black	Release button: Black Body: Black	PM Others

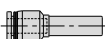
Different diameter type fittings

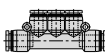
PEG 6 - 4 □
① ② ③ ④

① Model					② Port size I	③ Port size II	④ Standard color	
PG: Different diameter straight 	PZG: Different diameter cross 	PEW: Different diameter tee 	PYW: Different diameter union "Y" 	PGJ: Plug-in reducer 	4: Φ4mm 6: Φ6mm 8: Φ8mm 10: Φ10mm 12: Φ124mm	4: Φ4mm 6: Φ6mm 8: Φ8mm 10: Φ10mm	Standard color	Specification
PEG: Different diameter tee 	PKG: Reducer triple branch union 	PHK: Universal reducer triple branch union 	PHD: Universal reducer four branch union 				Blank: Gray	Release button: Gray Body: Gray
						D: Black	Release button: Black Body: Black	

Specification

Operating pressure range	0~10kgf/cm ² (0~1.0MPa)
Negative pressure	-750mmHg(10Torr)
Proof pressure	1.5MPa
Ambient and fluid temperature (°C)	-20~70
Applicable tubing	Soft nylon or polyurethane
Color	Grey/black

Product feature

- Variable models can be widely used in every kind of pneumatic systems.
- High circulation performance: bear the same flow with the volume of the tubing inside diameter.
- Connect tubing easily and conveniently. The tubing connection portion is safe and durable.
- The threaded portion is covered with sealant and the M5 thread is attached with a sealing gasket to prevent air leakage over the connection thread portion.

Inner structure

PM Series

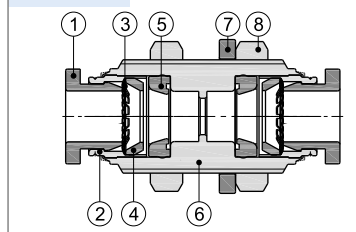

No.	Item	Material
1	Release button	POM
2	Guide	Aluminum alloy
3	Spring gasket	Stainless steel
4	Chuck	POM
5	O-ring	NBR
6	Body	Aluminum alloy
7	Rubber washer	NBR
8	Nut	Aluminum alloy

Table for interface port and tube O.D.

Product series	Port size I	Port size II				
		Φ4	Φ6	Φ8	Φ10	
PG PGJ	Φ4					
	Φ6	●				
	Φ8	●	●			
	Φ10		●	●		
	Φ12			●	●	
PEG PEW PYW	Φ4					
	Φ6	●				
	Φ8		●			
	Φ10			●		
	Φ12			●	●	
PZG	Φ4					
	Φ6	●				
	Φ8		●			
	Φ10			●		
	Φ12				●	
PKG	Φ4					
	Φ6	●				
	Φ8		●			
	Φ10			●		
	Φ12				●	
PHK PHD	Φ4					
	Φ6					
	Φ8		●			
	Φ10			●		
	Φ12				●	
Product series		Port size				
		Φ4	Φ6	Φ8	Φ10	Φ12
PE, PY, PV, PU PM, PLM, PP, PZ		●	●	●	●	●

Dimensions

PE Series

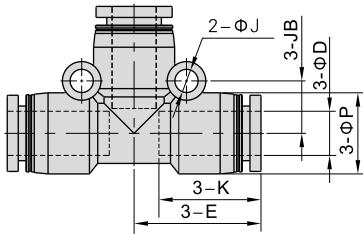

Model\Item	ΦD	ΦP	K	E	ΦJ	JB	Weight(g)
PE4	4	9	14	17	3.2	6.5	3.1
PE6	6	12.5	16.5	20	3.2	8	6.1
PE8	8	15	18.5	23	4.3	9.5	8.8
PE10	10	18	21	26.5	4.3	11	13.8
PE12	12	21	23	30	4.3	13	21

PU Series

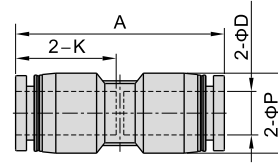

Model\Item	ΦD	ΦP	K	A	Weight(g)
PU4	4	9	14	29.5	1.7
PU6	6	12.5	16.5	34	3.6
PU8	8	15	18.5	38.5	5
PU10	10	18	21	43	8.1
PU12	12	21	23	47	12

PY Series

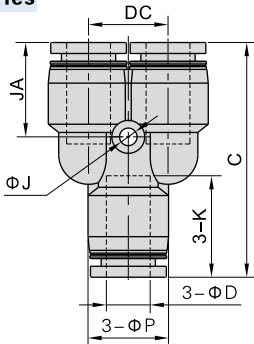

Model\Item	ΦD	ΦP	C	K	ΦJ	JA	DC	Weight(g)
PY4	4	9	31.5	14	3.2	13	10	3
PY6	6	12.5	37	16.5	3.2	15.5	12	6
PY8	8	15	42.5	18.5	3.2	17	14.5	8.6
PY10	10	18	48.5	21	4.3	19.5	18	14
PY12	12	21	54.5	23	4.3	21	20.5	21.2

PM Series

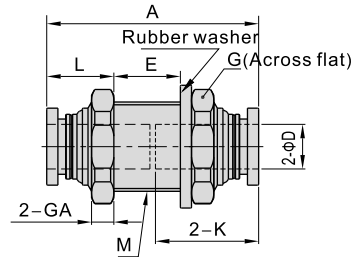

Model\Item	ΦD	M	A	K	L	E	GA	G	Weight(g)
PM4	4	M12X1	29	14	10	7	4	14	6.2
PM6	6	M14X1	34	16.5	10.5	11	4	17	9.5
PM8	8	M16X1	38	18.5	11.5	13	4	19	15.7
PM10	10	M20X1	43	21	12.5	16	5	24	22.5
PM12	12	M22X1	46.5	23	13.5	17.5	6	27	29.5

PV Series

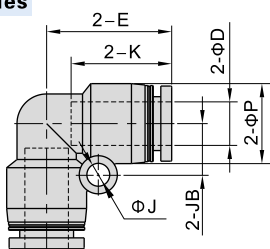

Model\Item	ΦD	ΦP	K	E	ΦJ	JB	Weight(g)
PV4	4	9	14	17	3.2	6.5	1.9
PV6	6	12.5	16.5	20	3.2	8	4.2
PV8	8	15	18.5	23	4.3	9.5	6
PV10	10	18	21	26.5	4.3	11	9.3
PV12	12	21	23	30	4.3	13	14.6

PLM Series

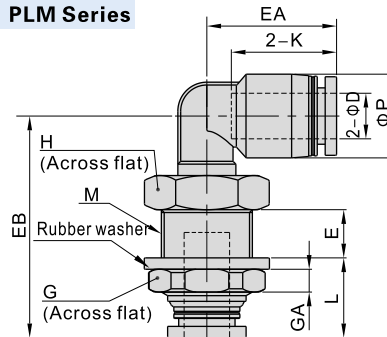

Model\Item	ΦD	ΦP	M	L	E	K	EA	EB	GA	G	H	Weight(g)
PLM4	4	9	M12X1	12	7.5	14	17	31	4	14	14	7.5
PLM6	6	12.5	M14X1	12.5	8.5	17	20	35.5	4	17	17	12.1
PLM8	8	15	M16X1	13.5	9	18.5	23	39	4	19	19	16.6
PLM10	10	18	M20X1	14.5	11	21	25.5	44.5	5	24	22	26.2
PLM12	12	21	M22X1	15.5	11	23	29.5	48	6	27	24	34

PYW Series

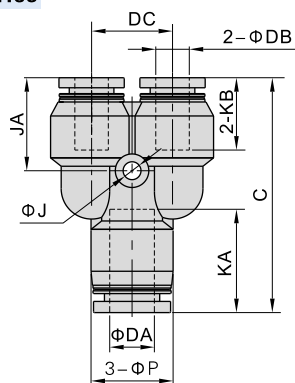

Model\Item	ΦDA	ΦDB	C	ΦP	KA	KB	ΦJ	JA	DC	Weight(g)
PYW6-4	6	4	36.5	12.5	16.5	14	3.2	15	12	5.8
PYW8-6	8	6	42	15	18.5	16.5	3.2	16.5	14.5	9.1
PYW10-8	10	8	48.5	18	21	18.5	4.3	19	18	14.1
PYW12-8	12	8	54	21	23	18.5	4.3	20.5	20.5	22.3
PYW12-10	12	10	54.5	21	23	21	4.3	21	20.5	21.7

PEG Series

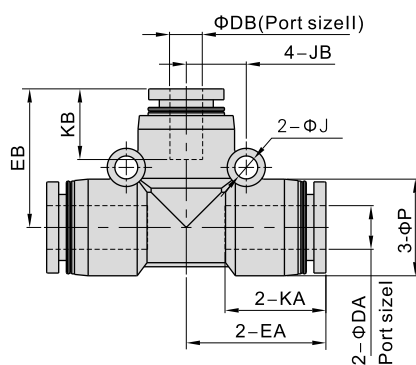

Model\Item	ΦDA	ΦDB	ΦP	KA	KB	EA	EB	ΦJ	JB	Weight(g)
PEG6-4	6	4	12.5	16.5	14	20.0	19.5	3.2	8	7
PEG8-6	8	6	15	18.5	16.5	22.5	22	4.3	9.5	22.8
PEG10-8	10	8	18	21	18.5	25.5	25.5	4.3	11	15.1
PEG12-8	12	8	21	23	18.5	29	28.5	4.3	13	2.2
PEG12-10	12	10	21	23	21	29	29	4.3	13	21.5

PZ Series

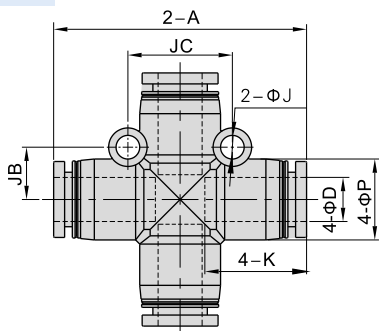

Model\Item	ΦD	A	ΦP	K	ΦJ	JB	JC	Weight(g)
PZ4	4	34	9	14	3.2	6.5	13	3.9
PZ6	6	39.5	12.5	16.5	3.2	8	16	7.9
PZ8	8	46	15	18.5	4.3	9.5	19	11.1
PZ10	10	52.5	18	21	4.3	11	22	17.5
PZ12	12	59.5	21	23	4.3	13	26	26.6

PEW Series

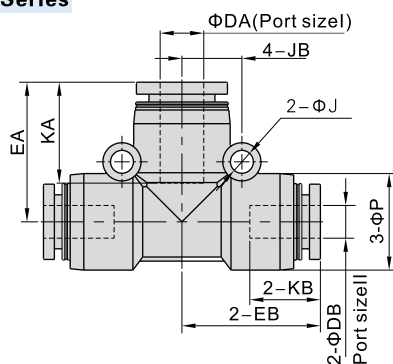

Model\Item	ΦDA	ΦDB	ΦP	KA	KB	EA	EB	ΦJ	JB	Weight(g)
PEW6-4	6	4	12.5	16.5	14	20	19.5	3.2	8	7
PEW8-6	8	6	15	18.5	16.5	22.5	22	4.3	9.5	22.8
PEW10-8	10	8	18	21	18.5	25.5	25.5	4.3	11	15.1
PEW12-8	12	8	21	23	18.5	29	28.5	4.3	13	2.2
PEW12-10	12	10	21	23	21	29	29	4.3	13	21.5

PG Series

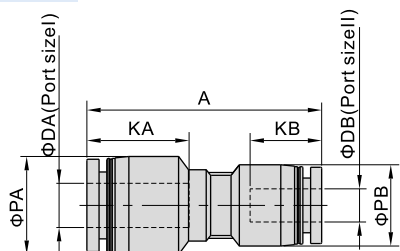

Model\Item	ΦDA	ΦDB	ΦPA	ΦPB	KA	KB	A	Weight(g)
PG6-4	6	4	12.5	9	16.5	14	33.5	2.7
PG8-4	8	4	15	12.5	18.5	14	37.5	4.5
PG8-6	8	6	15	12.5	18.5	16.5	38	4.5
PG10-6	10	6	18	15	21	16.5	42	6.9
PG10-8	10	8	18	15	21	18.5	42.5	6.7
PG12-8	12	8	21	18	23	18.5	46.5	10.3
PG12-10	12	10	21	18	23	21	47	10.2

PP Series

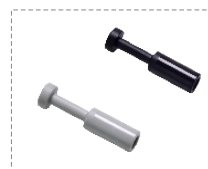
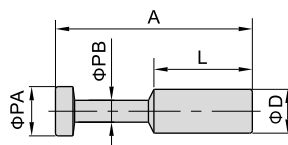

Model\Item	ΦD	ΦPA	ΦPB	L	A	Weight(g)
PP4	4	5	3	15	27.5	0.7
PP6	6	7	3	17	32	0.9
PP8	8	9	4	18	36	1.6
PP10	10	11	5	20	42	2.5
PP12	12	13	6	23	44	4.3

PGJ Series

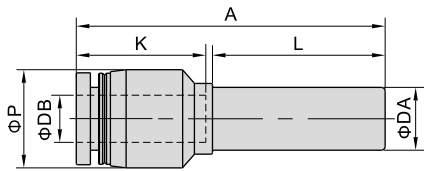

Model\Item	ΦDA	ΦDB	ΦP	K	L	A	Weight(g)
PGJ6-4	6	4	9	14	21	35	1.5
PGJ8-4	8	4	12.5	14	22	39	2.6
PGJ8-6	8	6	12.5	16.5	22	39.5	3.2
PGJ10-6	10	6	15	16.5	25	44	4.1
PGJ10-8	10	8	15	18.5	25	44.5	3.9
PGJ12-8	12	8	18	18.5	26	48.5	6.2
PGJ12-10	12	10	18	21	26	49	6

PZG Series

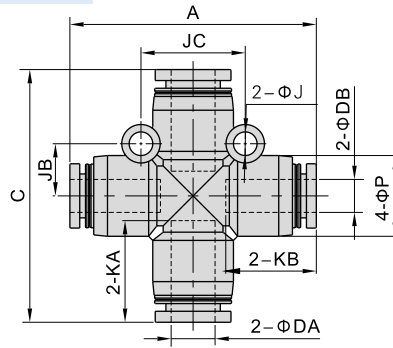

Model\Item	ΦDA	ΦDB	A	C	ΦP	KA	KB	ΦJ	JB	JC	Weight(g)
PZG6-4	6	4	39	39.5	12.5	16.5	14	3.2	8	16	8.2
PZG8-6	8	6	45	46	15	18.5	16.5	4.3	9.5	19	12
PZG10-8	10	8	52	52.5	18	21	18.5	4.3	11	22	18.1
PZG12-10	12	10	59	59.5	21	23	21	4.3	13	26	29

PHK Series

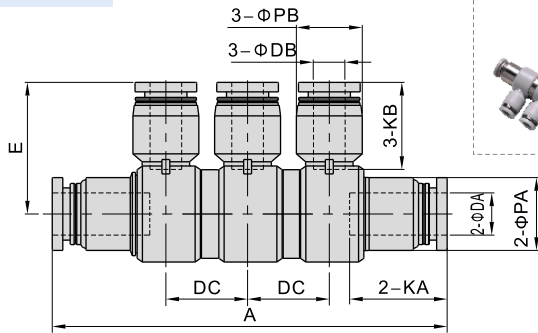

Model\Item	ΦDA	ΦDB	A	ΦPA	ΦPB	KA	KB	DC	E	Weight(g)
PHK8-6	8	6	75	14	12.5	18.5	16.5	15.5	25	28.4
PHK10-8	10	8	85.5	17	15	21	18.5	16.5	29.5	45

PHD Series

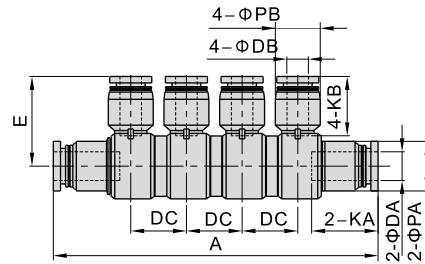

Model\Item	ΦDA	ΦDB	A	ΦPA	ΦPB	KA	KB	DC	E	Weight(g)
PHD8-6	8	6	90.5	14	12.5	18.5	16.5	15.5	25	18.7
PHD10-8	10	8	102.5	17	15	21	18.5	16.5	29.5	52.7

PKG Series

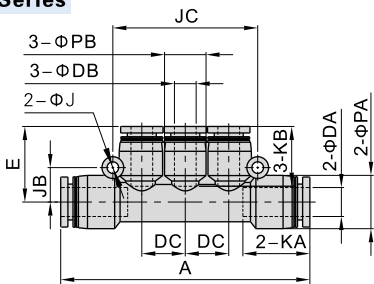

Model\Item	ΦDA	ΦDB	A	ΦPA	ΦPB	KA	KB	ΦJ	JB	JC	DC	E	Weight(g)
PKG6-4	6	4	58	12.5	9	16.5	14	3.2	8	34	10	17.5	8.6
PKG8-6	8	6	69	15	12.5	18.5	16.5	3.2	9.5	40	12	21	13.5
PKG10-8	10	8	80	18	15	21	18.5	4.3	11	48	14.5	24	20.7

Ordering code

BB 01 01 □

① ② ③ ④

① Model	② Thread connection I	③ Thread connection II	④ Thread type
BB: Male connector 	BD: Male & female connector[Note1] 	BU: Double female connector 	BZ: Hexagon head cap plug[Note2]
	01: 1/8" 02: 1/4" 03: 3/8" 04: 1/2"	01: 1/8" 02: 1/4" 03: 3/8" 04: 1/2"	Blank: PT

[Note1] For BD series, Thread I is Female thread, Thread II is male thread; [Note2] For BZ series, no thread II and thread I is male thread.

Specification

Operating pressure range	0~10kgf/cm²(0~1.0MPa)
Negative pressure	-750mmHg(10Torr)
Proof pressure	3.0MPa
Ambient and fluid temperature (°C)	0~150

Configuration table of tubing thread

Product series	Thread connection I	Thread connection II			
		01	02	03	04
BB	01	●	●	●	●
	02		●	●	●
	03			●	●
	04				●
BD	01		●	●	●
	02			●	●
	03				●
	04				
BU	01	●			
	02		●		
	03			●	
	04				●
Product series	Thread connection				
	01	02	03	04	
BZ	●	●	●	●	

Product feature

- Variable models can be widely used in every kind of pneumatic systems.
- High circulation performance bear the same flow with the volume of the tube innerdiameter.
- The nickel plated body is anti-corrosion and anti-pollution, which allows a broader application.
- Metal fittings can be used in high temperature environment.

Dimensions

BB Series

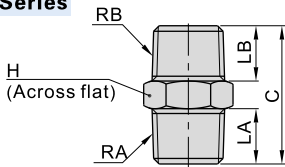

Model\Item	RA	RB	LA	LB	C	H	Weight(g)
BB0101	1/8"	1/8"	7.5	7.5	19.5	10	6.6
BB0102	1/4"	1/8"	10	7.5	22.5	14	12.1
BB0103	3/8"	1/8"	11	7.5	24	17	18.3
BB0202	1/4"	1/4"	10	10	25	14	14.6
BB0203	3/8"	1/4"	11	10	26.5	17	20.3
BB0204	1/2"	1/4"	14	10	30	21	34.3
BB0303	3/8"	3/8"	11	11	27.5	17	23.2
BB0304	1/2"	3/8"	14	11	31	21	36.2
BB0404	1/2"	1/2"	14	14	34	21	42.8

BD Series

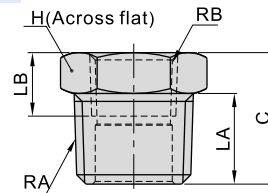

Model\Item	RA	RB	LA	LB	C	H	Weight(g)
BD0102	1/4"	1/8"	10	8	14.5	14	8.8
BD0103	3/8"	1/8"	11	8	16	17	17.1
BD0104	1/2"	1/8"	14	8	19.5	21	33.1
BD0203	3/8"	1/4"	11	11	16	17	12.7
BD0204	1/2"	1/4"	14	11	19.5	21	29.9
BD0304	1/2"	3/8"	14	12	19.5	21	22.5

BU Series

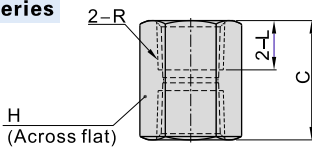

Model\Item	R	L	C	H	Weight(g)
BU0101	1/8"	8	17	12	8.4
BU0202	1/4"	11	23	17	25.4
BU0303	3/8"	12	25	21	40
BU0404	1/2"	13.5	28	24	46.6

BZ Series

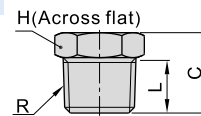

Model\Item	R	L	C	H	Weight(g)
BZ01	1/8"	7.5	11	10	4.6
BZ02	1/4"	10	14.5	14	10.8
BZ03	3/8"	11	16	17	17.4
BZ04	1/2"	14	19.5	21	33

Ordering code

BKC 06 04 - 01 □

1 2 3 4 5

① Model	② Tubing outer diameter	③ Tubing inner diameter	④ Thread connection	⑤ Thread type
BKC: Straight locknut connector 	04: Φ4mm 06: Φ6mm 08: Φ8mm 10: Φ10mm 12: Φ12mm	25: Φ2.5mm 04: Φ4mm 05: Φ5mm 06: Φ6mm 65: Φ6.5mm 75: Φ7.5mm 08: Φ8mm 09: Φ9mm	M3: M3X0.5 M5: M5X0.8 01: 1/8" 02: 1/4" 03: 3/8" 04: 1/2"	Blank: PT

Note: When using the tubing Φ8×Φ5.5, the straight lock nut connector of BKC0806 can be used.

Specification

Operating pressure range	0~10kgf/cm ² (0~1.0MPa)
Negative pressure	-750mmHg(10Torr)
Proof pressure	3.0MPa
Ambient and fluid temperature (°C)	0~150

Note: The temperature resistance level of the tubing should be confirmed first when used in high temperature environments.

Product feature

1. Variable models can be widely used in every kind of pneumatic systems.
2. High circulation performance bear the same flow with the volume of the tube innerdiameter.
3. The nickel plated body is anti-corrosion and anti-pollution, which allows a broader application.
4. Metal fittings can be used in high temperature environments.

Dimensions

BKC Series

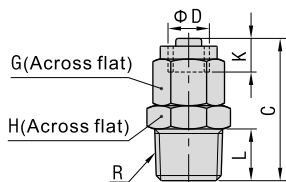

Model\Item	Tubing diameterΦD		R	L	C	K	G	H	Weight(g)	Model\Item	Tubing diameterΦD		R	L	C	K	G	H	Weight(g)
	O.D	I.D									O.D	I.D							
BKC0425-M3	4	2.5	M3×0.5	3	17	5	8	8	4.4	BKC1065-02	10	6.5	1/4"	10	30	7.5	15	15	25.3
BKC0425-M5			M5×0.8	3.5	17.5			8	4.8	BKC1065-03			3/8"	11	31.5			17	29.1
BKC0425-01	6	4	1/8"	7.5	20.5	5.5	10	10	7.1	BKC1065-04	10	7.5	1/2"	14	35.5	7.5	15	21	44
BKC0604-01			1/8"	7.5	22			10	9.9	BKC1075-02			1/4"	10	30			15	24.1
BKC0604-02	6	4	1/4"	10	25.5	5.5	10	14	15.8	BKC1075-03	10	8	3/8"	11	31.5	7.5	15	17	28.9
BKC0604-03			3/8"	11	27			17	22.5	BKC1075-04			1/2"	14	35.5			21	43.6
BKC0805-01	8	5	1/8"	7.5	24	6.5	12	12	12.8	BKC1208-02	12	8	1/4"	10	30	7.5	17	17	30.5
BKC0805-02			1/8"	7.5	27.5			14	17.2	BKC1208-03			3/8"	11	31.5			17	32.1
BKC0805-03	8	5	3/8"	11	29	6.5	12	17	23.7	BKC1208-04	12	8	1/2"	14	35.5	7.5	17	21	46.7
BKC0806-01			1/8"	7.5	24			12	13.1	BKC1209-02			g	10	30			17	30.6
BKC0806-02	8	5.5or6	1/4"	10	27.5	6.5	12	14	17.2	BKC1209-03	12	g	3/8"	11	31.5	7.5	17	17	31.9
BKC0806-03			3/8"	11	29			17	23.6	BKC1209-04			10	1/2"	14			35.5	21

Installation and application

1. Method of inserting or removal a tubing
 - 1.1 Inserting a tubing
Place the locking cap over the tubing, and insert the tubing into the body, then tighten the locking cap. (As figure 1)
 - 1.2 Removing a tubing
Loosen the locking cap first, then remove the tubing. (As figure 2)
2. Method of tightening the connector thread
Tighten the connector with a hex wrench, as shown right.

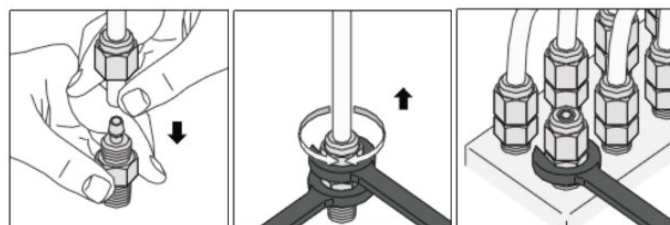

Figure 1

Figure 2

Figure 3

Ordering code

BSL 01 □

① ② ③

① Silencer Type	② Thread connection	③ Standard color		
BSL: Universal silencer BSLM: Mini Silencer BESL: Throttling silencer PAL: Plastic silencer PALM: Mini plastic Silencer	M5: M5X0.8 01: 1/8" 02: 1/4" 03: 3/8" 04: 1/2"	Type	Color code	Color definition
		PAL、PALM	Blank: grey	Top cover: grey/Body: grey
		Others	D: Black	Top cover: black/Body: black
			No such code	

Product feature

BSL、BSLM、BESL Series:

1. This silencers have excellent noise silencing performance.
2. The installation of the silencer is simple and convenient, and the connecting portion is reliable and durable.
3. It is easy to adjust the exhaust flow of the throttling type silencer.

PAL Series、PALM Series:

1. The silencer body is made of plastic.
2. The mini type silencer has the characteristics of small volume and compact structure.

Configuration table of tubing thread

Product series	Thread connection				
	M5	01	02	03	04
BSL	●	●	●	●	●
BSLM	●	●	●	●	●
BESL		●	●	●	●
PAL		●	●	●	●
PALM		●	●		

Specification

Model	BSLM5	BSL01	BSL02	BSL03	BSL04	BSLMM5	BSLM01	BSLM02	BSLM03	BSLM04
Thread connection	M5×0.8	1/8"	1/4"	3/8"	1/2"	M5×0.8	1/8"	1/4"	3/8"	1/2"
Silencing effect(dB)(0.5MPa)	15	20	20	20	12	15	20	20	20	20
Model	BESL01	BESL02	BESL03	BESL04	PAL01	PAL02	PAL03	PAL04	PALM01	PALM02
Thread connection	1/8"	1/4"	3/8"	1/2"	1/8"	1/4"	3/8"	1/2"	1/8"	1/4"
Silencing effect(dB)(0.5MPa)	20	20	20	20	25	25	25	25	25	25
Operating pressure	0~10kgf/cm ² (0~1.0MPa)									
Negative pressure	-750mmHg(10Torr)									
Proof pressure	1.5MPa									
Temperature range	-20~70℃									

Inner structure

BSL Series

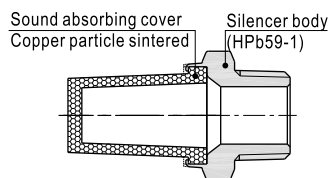

BESL Series

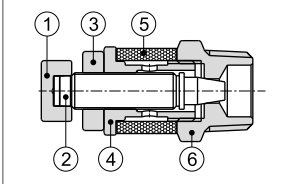

NO.	Name	Material
1	Adjusting cap	Aluminum alloy
2	Throttling column	Aluminum alloy
3	Locking cap	Aluminum alloy
4	Locking ring	Aluminum alloy
5	Silencer ring	Copper particle sintered
6	Silencer body	Brass

PAL Series

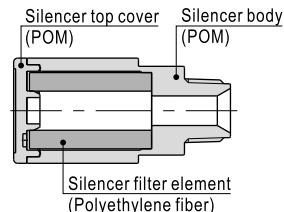

Flowrate characteristic

BSL Series

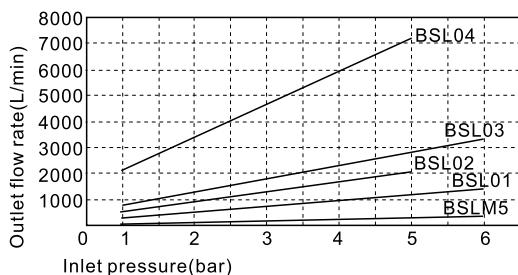

BSLM Series

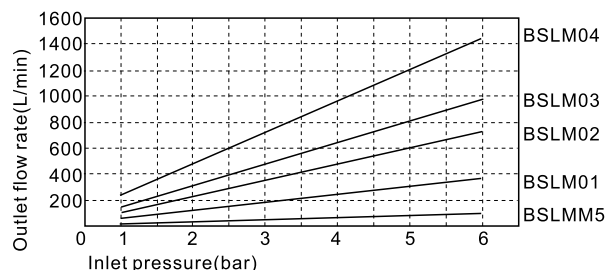

Flowrate characteristic

PAL、PALM Series

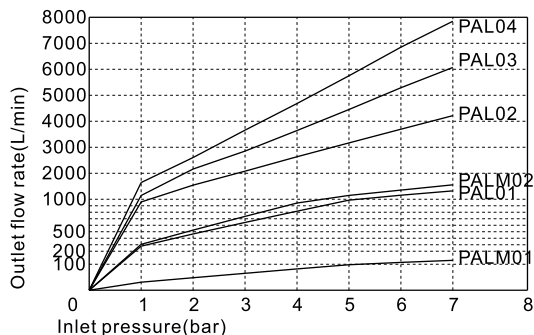

BESL Series (Inlet pressure and outlet flow rate)

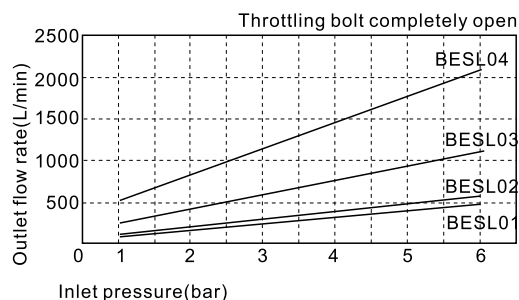

BESL Series

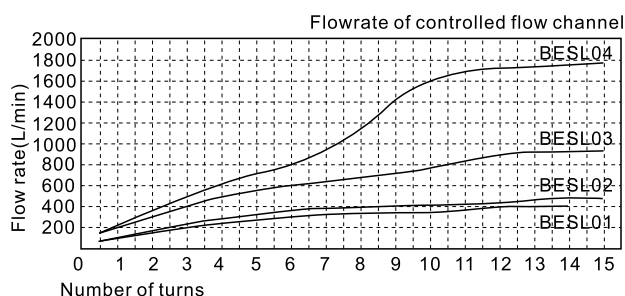

Dimensions

BSL Series

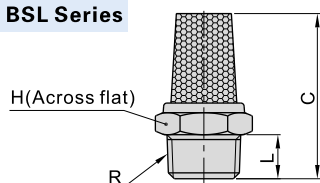

Model/Item	R	L	C	H	Weight(g)
BSLM5	M5×0.8	3.5	19.5	8	2.9
BSL01	1/8"	6	24	12	6.7
BSL02	1/4"	8	30	15	11.6
BSL03	3/8"	9	38.5	19	22
BSL04	1/2"	10.5	46	22	35

BSLM Series

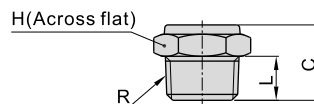

Model/Item	R	L	C	H	Weight(g)
BSLMM5	M5×0.8	3.5	9.5	8	2.3
BSLM01	1/8"	6	11	12	4.3
BSLM02	1/4"	8	13.5	15	8.4
BSLM03	3/8"	9	15.5	19	15.8
BSLM04	1/2"	10.5	19	22	25.9

BESL Series

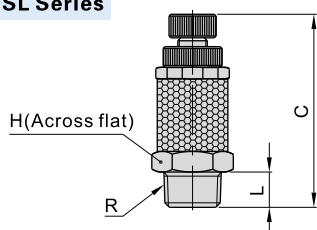

Model/Item	R	L	C		H	Weight(g)
			max	min		
BESL01	1/8"	6	40.5	33	12	10
BESL02	1/4"	8	42.5	35	14	18.1
BESL03	3/8"	9	49	41.5	17	31.1
BESL04	1/2"	10.5	59.5	52	24	69.8

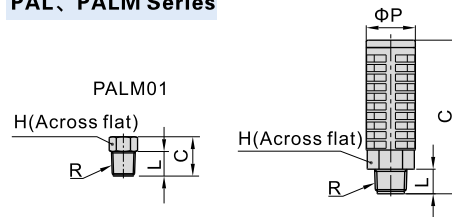

PAL、PALM Series



Model/Item	R	ΦP	L	C	H	Weight(g)
PAL01	1/8"	16	7	33	14	4.2
PALM01	1/8"	/	10	16	10	0.9
PAL02	1/4"	20	10	62.5	17	10.7
PALM02	1/4"	16	10	36	14	5.1
PAL03	3/8"	26	12	68	24	20
PAL04	1/2"	28	12	73	24	23.1

Ordering code

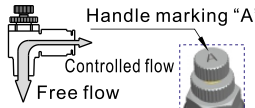
PSL 6 01 A □ □
 ① ② ③ ④ ⑤ ⑥

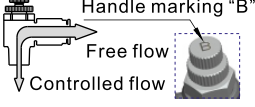
① Model	② Port size	③ Thread connection		④ Control method	⑤ Standard color		⑥ Thread type
PSL: Speed controller 	4: Φ 4mm 6: Φ 6mm 8: Φ 8mm 10: Φ 10mm 12: Φ 12mm	Thread	Adaptable port size	A: Meter-out 	Standard color	Specification	Blank: PT
PSS: Universal speed controller 		M5: M5X0.8	Φ 4, Φ 6	B: Meter-in 	Blank: Gray	Release button: Gray Body: Gray	
		01: 1/8" 02: 1/4" 03: 3/8" 04: 1/2"	Φ 4, Φ 6 Φ 8, Φ 10 Φ 12		D: Black	Release button: Black Body: Black	

PSA 6 □

① ② ③

① Model	② Port size	③ Standard color	
PSA: Straight speed controller 	4: Φ 4mm 6: Φ 6mm 8: Φ 8mm 10: Φ 10mm 12: Φ 12mm	Standard color	Specification
		Blank: Gray	Release button: Gray Body: Gray
		D: Black	Release button: Black Body: Black

Product feature

1. The silencer is small size, and light weight with small installation space.
2. Excellent flow characteristics, high sensitivity and easy to adjust.
3. The silencer brass body adopts a special nickel-plating process, which has good corrosion resistance and anti-pollution property.
4. Anti-drop structure is designed on the regulating rod.
5. The sealant being coated on threaded portion can ensure no leakage of the threaded connection part.
6. The inserting direction of universal speed controller can be adjusted in 360°.

Specification

Operating pressure range	0~10kgf/cm ² (0~1.0MPa)
Negative pressure	-750mmHg(10Torr)
Proof pressure	1.5MPa
Ambient and fluid temperature (°C)	-20~70
Applicable tubing	Soft nylon or polyurethane
Color	Grey/black

Table for interface port and tube O.D.

Product series	Thread type	Port size				
		Φ 4	Φ 6	Φ 8	Φ 10	Φ 12
PSA	-	●	●	●	●	●
	M5	●	●	●		
	1/8"	●	●	●		
PSL	1/4"		●	●	●	
	3/8"		●	●	●	●
	1/2"			●	●	●
	M5	●				
PSS	1/8"		●	●		
	1/4"		●	●	●	
	3/8"				●	●
	1/2"					●

Symbol

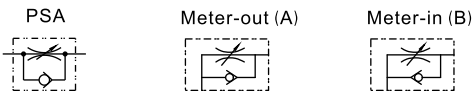

Inner structure

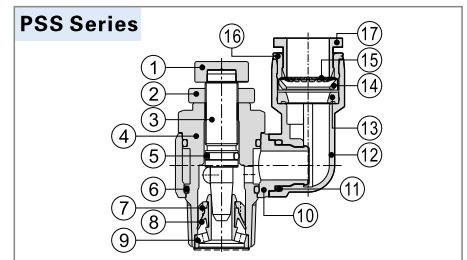
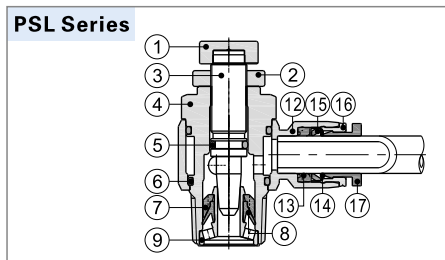
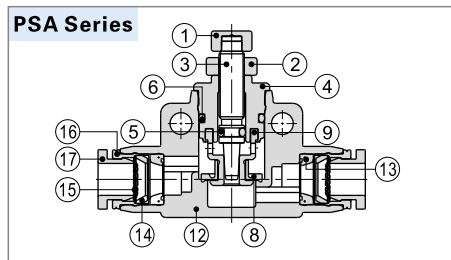

NO.	Name	Material	NO.	Name	Material	NO.	Name	Material
1	Adjusting cap	Aluminum alloy	7	Holder	PBT	13	O-ring	NBR
2	Locking cap	Aluminum alloy	8	O-ring	NBR	14	Locating seat	POM
3	Throttling column	Brass	9	Throttling sleeve	Aluminum alloy/Brass	15	Spring gasket	Stainless steel
4	Throttling body	Brass	10	Plastic body	PBT	16	Locating ring	Aluminum alloy
5	O-ring	NBR	11	O-ring	NBR	17	Plastic interface	POM
6	O-ring	NBR	12	Plastic body	PBT			

Dimensions

PSL Series

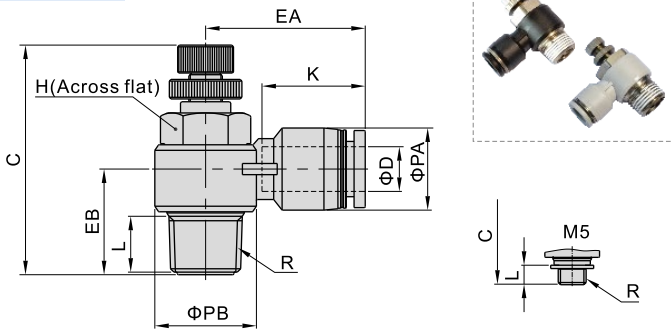

PSS Series

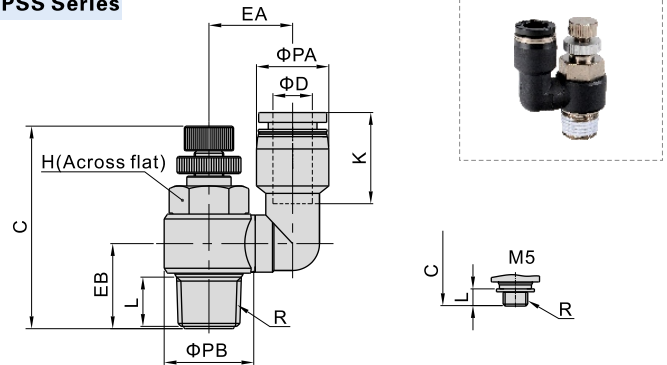

Model/Item [Note1]	ΦD	R	ΦPA	ΦPB	L	C		K	EA	EB	H	Weight (g)
						max	min					
PSL4M5□	4	M5×0.8	9	10	3.5	30	27.5	14	19	9.5	8	6.5
PSL401□		1/8"	9	14	7.5	41.5	35	14	20.5	15	11	16.5
PSL6M5□	6	M5×0.8	12.5	10	3.5	30	27.5	16.5	23.5	11.5	8	8
PSL601□		1/8"	12.5	14	7.5	41.5	35	16.5	23	15.5	11	17.5
PSL602□	6	1/4"	12.5	18	10	47.5	41	16.5	25	18	14	32
PSL603□		3/8"	12.5	22.5	11	52.5	45.5	16.5	27	20	19	59.5
PSL801□	8	1/8"	15	14	7.5	41.5	35	18.5	26.5	16.5	11	18
PSL802□		1/4"	15	18	10	47.5	41	18.5	28.5	19	14	33
PSL803□		3/8"	15	22.5	11	52.5	45.5	18.5	29.5	20	19	60
PSL804□		1/2"	15	28	14	58.5	51.5	18.5	32	25	24	96.5
PSL1002□	10	1/4"	18	18	10	47.5	41	21	31	20.5	14	34.5
PSL1003□		3/8"	18	22.5	11	52.5	45.5	21	33	21.5	19	62
PSL1004□		1/2"	18	28	14	58.5	51.5	21	35.5	25.5	24	98
PSL1203□		12	3/8"	21	22.5	11	52.5	45.5	23	36	23.5	19
PSL1204□	1/2"		21	28	14	58.5	51.5	23	38	27	24	100

[Note1] "□" stands for A or B. A indicates meter-out type while B indicates meter-in type. The two types are with the same overall dimension.

Model/Item [Note1]	ΦD	R	ΦPA	ΦPB	L	C		K	EA	EB	H	Weight (g)
						max	min					
PSS4M5□	4	M5×0.8	9	10	3.5	30	27.5	14	12.5	9.5	8	8.1
PSS601□	6	1/8"	12.5	14	7.5	41.5	35	17	17	15	11	19
PSS602□		1/4"	12.5	18	10	47.5	41	17	19	17.5	14	34.7
PSS801□	8	1/8"	15	14	7.5	41.5	35	18.5	17	15	11	20.2
PSS802□		1/4"	15	18	10	47.5	41	18.5	19	17.5	14	39.8
PSS1002□	10	1/4"	18	18	10	47.5	41	21	20.5	17.5	14	37.2
PSS1003□		3/8"	18	22.5	11	52.5	45.5	21	24	20	19	66
PSS1203□	12	3/8"	21	22.5	11	52.5	45.5	23	25.5	20	19	69.2
PSS1204□		1/2"	21	28	14	58.5	51.5	23	28	25	24	105.8

[Note1] "□" stands for A or B. A indicates meter-out type while B indicates meter-in type. The two types are with the same overall dimension.

PSA Series

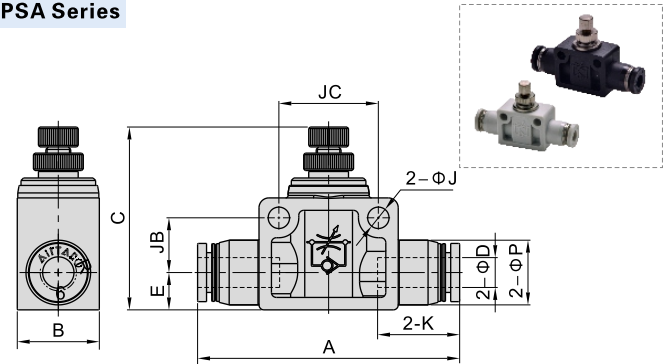

Model/Item	ΦD	A	B	C		ΦP	E	K	ΦJ	JB	JC	Weight (g)
				max	min							
PSA4	4	41	11	29	26.5	9.5	7	14	3.2	6	14	7.85
PSA6	6	52.5	16.5	43.5	36.5	13	7.5	16.5	4.3	11	20	18.3
PSA8	8	59.5	16.5	47	40	15	8.5	18.5	4.3	11	22	23.5
PSA10	10	69	21	53.5	46.5	18	10.5	21	4.3	14.5	26	42.4
PSA12	12	78.5	26	58.5	51	21.5	12	23	4.3	17.5	32	67.5

Flowrate characteristic

Controlled flow rate

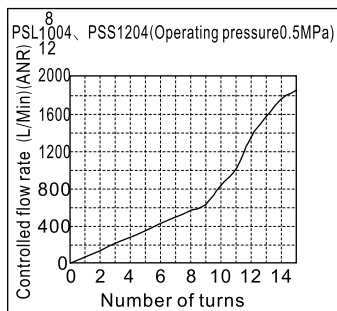
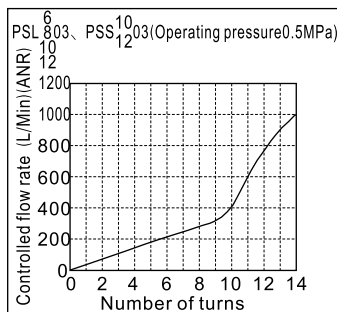
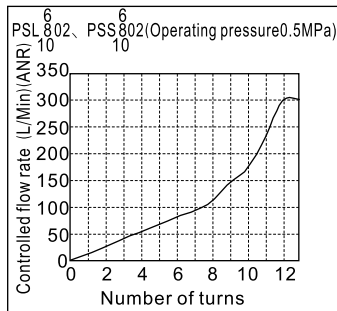
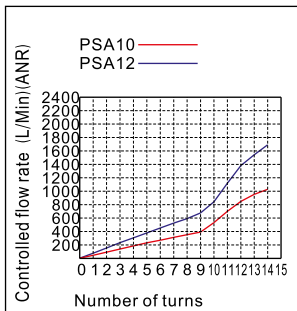
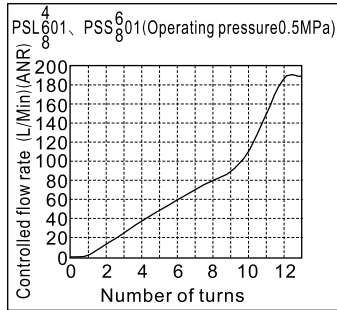
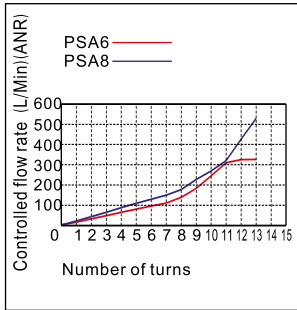
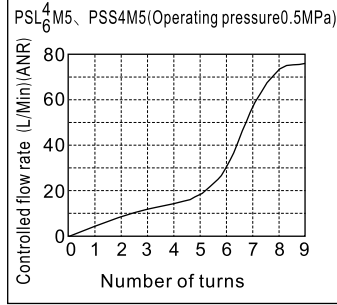
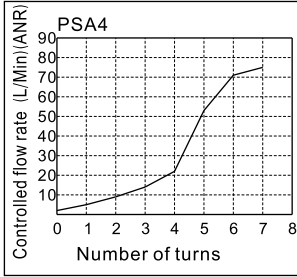



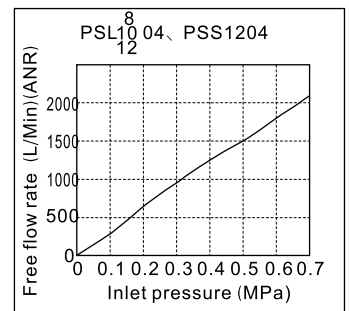
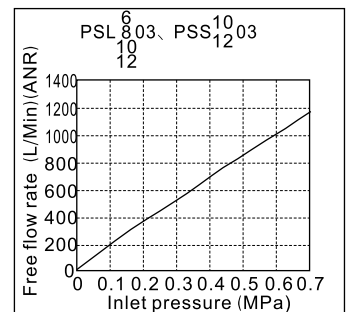
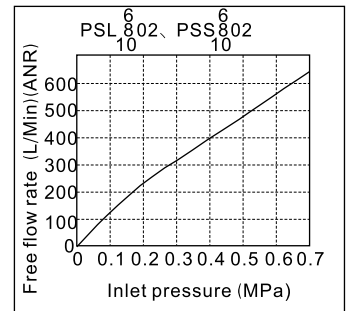
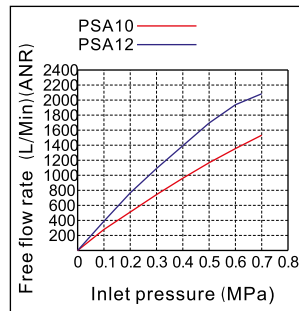
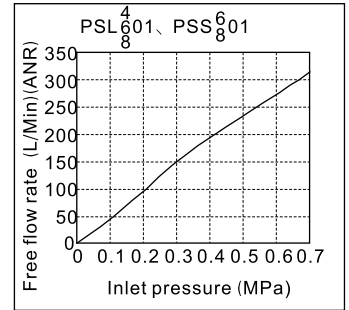
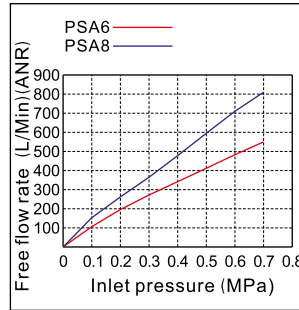
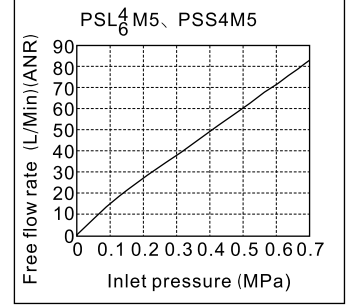
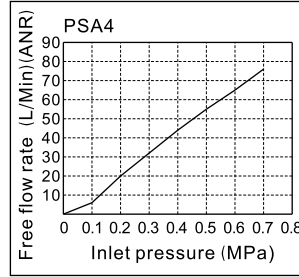

Free flow rate



Selection, Installation and Operation

Selection

- The speed controller has meter-out type and meter-in type:

	Working principle	Product identification
 <p>Controlled flow Free flow</p>	<p>A: Meter-out</p> <ol style="list-style-type: none"> The air flow is controlled from the threaded end to tubing connection end. The air flow is free from the tubing connection end to the threaded end. 	<p>Handle marking "A"</p> 
 <p>Free flow Controlled flow</p>	<p>B: Meter-in</p> <ol style="list-style-type: none"> The air flow is free from the threaded end to tubing connection end. The air flow is controlled from the tubing connection end to the threaded end. 	<p>Handle marking "B"</p> 

- Select the different control method according to the actual requirement. The meter-out type is the first priority.

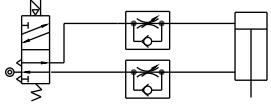
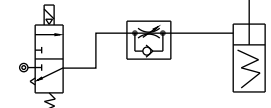
2.1. The application example of the meter-out speed controller	2.2. The application example of the meter-in speed controller
<p>Solenoid valve Double acting cylinder</p>  <p>Meter-out speed controller</p>	<p>Solenoid valve Single acting cylinder</p>  <p>Meter-in speed controller</p>

Installation

- Installation and removal of tubing:

- 1.1. Installation of tubing

Grasp the tubing and slowly push it into the fitting until it comes to a stop. The tubing will be locked by the spring gasket.

- 1.2. Removal of tubing

Push the release button to open the spring gasket so that the tubing can be released.

Note: When remove the tubing, make sure the pressure in the tubing is Zero.

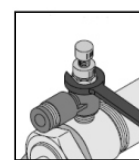
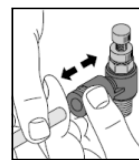
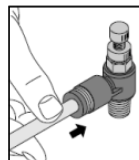

2. Mounting of the speed controller

Mount the speed controller into the inlet and outlet port of the cylinder with a wrench.

Note: Please refer to the fittings for the tightening torque and thread screw-in depth.

Operation

1. Adjustment of the cylinder speed

1.1. Make sure the speed controller is turned off before applying air pressure. The cylinder may fly out due to the high speed if the air is inlet when the speed controller is turned on.

1.2. Adjust the speed by opening the needle slowly from the fully closed state. When a needle valve is turned clockwise, the air flow through is reduced and the actuator speed decreases. When a needle valve is turned counter-clockwise, the air flow through is increased and the actuator speed increases.

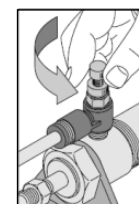
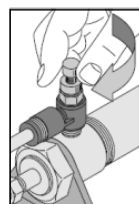

2. Operation of the speed controller

2.1. Do not use tools such as pliers to rotate the handle. Do not apply excessive force or shock when the needle is at the place of top or bottom. It can cause damage or air leakage.

2.2. A certain amount of leakage is allowed in the closed state of the speed controller. It is not designed for the use as stop valve with zero air leakage.

Ordering code

PTL 6 M5 A □ □ -M

① ② ③ ④ ⑤ ⑥ ⑦

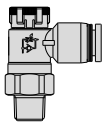
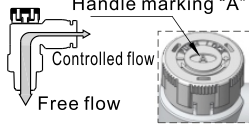
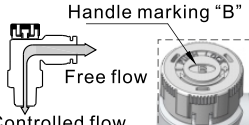
① Model	② Port size	③ Thread connection	④ Control method	⑤ Standard color	⑥ Thread type	⑦ Style
PTL: Speed controller (Push lock) 	4: Φ4mm 6: Φ6mm	M5: M5X0.8 01: 1/8"	A: Meter-out  Handle marking "A" Controlled flow Free flow B: Meter-in  Handle marking "B" Free flow Controlled flow	Standard color Specification Blank: Gray Release button: Gray Body: Gray D: Black Release button: Black Body: Black	Blank: PT	M: Mini type

Specification

Operating pressure range	0~10kgf/cm² (0~1.0MPa)
Negative pressure	-750mmHg(10Torr)
Proof pressure	1.5MPa
Ambient and fluid temperature (°C)	-20~70
Applicable tubing	Soft nylon or polyurethane
Color	Grey/black

Symbol

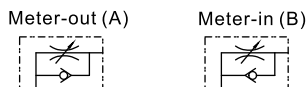

Selection, Installation and Operation

- The rotation torque of the push-lock speed controller cap should not be too large to avoid damage. It is recommended to use the torque below.

Thread size	Recommended torque(N.m)
M5	0.05
1/8"	0.08

- Push-lock speed controller installation instructions is the same as general one. Please refer to general type for specific content.

Dimensions

PTL Mini series

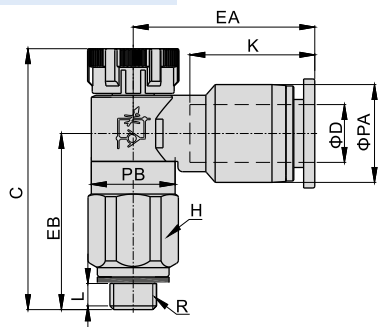

Model/Item [Note1]	ΦD	R	ΦPA	ΦPB	L	C		K	EA	EB	H	Weight (g)
						Pull	Push					
PTL4M5□-M	4	M5×0.8	8.5	9	3.5	29.5	28	12.5	16.5	19	9	5
PTL401□-M		1/8"	8.5	9	3.5	29.5	28	12.5	16.5	19	10	11
PTL6M5□-M	6	M5×0.8	10.5	9	3.5	29.5	28	13.5	19.5	19	9	6.2
PTL601□-M		1/8"	10.5	9	3.5	29.5	28	13.5	19.5	19	10	12

[Note1] "□" stands for A or B. A indicates meter-out type while B indicates meter-in type. The two types are with the same overall dimension.

Product feature

- Compare with standard speed controller, smaller size, lighter weight, suitable for more occasions.
- Effectively control the action speed and the pressure signal transmission from pneumatic device.
- Simple push-lock, operation.
- Adjust quickly, easily and accurately.
- Excellent flow rate characteristic, high sensitivity and easy to adjust.
- Options of Meter-out and meter-in, applicable for every type actuator.
- Effectively prevent from corrosion and pollution by nickel plated copper.
- The sealant being coated on threaded portion can ensure no leakage of the threaded connection part.

Table for interface port and tube O.D.

Product series	Thread type	Port size	
		Φ4	Φ6
PTL	M5	●	●
	1/8"	●	●

Ordering code

PTL 6 01 A
 ① ② ③ ④ ⑤ ⑥

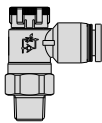
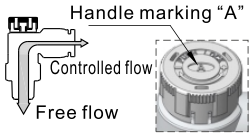
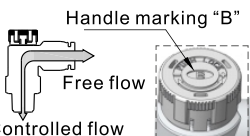
① Model	② Port size	③ Thread connection	④ Control method	⑤ Standard color	⑥ Thread type
PTL: Speed controller (Push lock) 	6: Φ6mm	01: 1/8" 02: 1/4" 03: 3/8"	A: Meter-out 	Standard color: Specification Blank: Gray Release button: Gray Body: Gray	Blank: PT
	8: Φ8mm	01: 1/8" 02: 1/4" 03: 3/8" 04: 1/2"	B: Meter-in 	D: Black Release button: Black Body: Black	
	10: Φ10mm	02: 1/4" 03: 3/8" 04: 1/2"			
	12: Φ12mm	03: 3/8" 04: 1/2"			

Specification

Operating pressure range	0~10kgf/cm²(0~1.0MPa)
Negative pressure	-750mmHg(10Torr)
Proof pressure	1.5MPa
Ambient and fluid temperature (°C)	-20~70
Applicable tubing	Soft nylon or polyurethane
Color	Grey/black

Product feature

1. Compare with standard speed controller, smaller size, lighter weight, suitable for more occasions.
2. Effectively control the action speed and the pressure signal transmission from pneumatic device.
3. Simple push-lock, operation.
4. Adjust quickly, easily and accurately.
5. Excellent flow rate characteristic, high sensitivity and easy to adjust.
6. Options of Meter-out and meter-in, applicable for every type actuator.
7. Effectively prevent from corrosion and pollution by nickel plated copper.
8. The sealant being coated on threaded portion can ensure no leakage of the threaded connection part.

Symbol

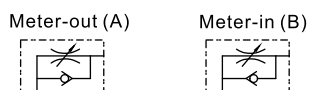

Table for interface port and tube O.D.

Product series	Thread type	Port size			
		Φ6	Φ8	Φ10	Φ12
PTL	1/8"	●	●		
	1/4"	●	●	●	
	3/8"	●	●	●	●
	1/2"		●	●	●

Selection, Installation and Operation

1. The rotation torque of the push-lock speed controller cap should not be too large to avoid damage. It is recommended to use the torque below.

Thread size	Recommended torque(N.m)
1/8"	0.08
1/4"	0.16
3/8"	0.24
1/2"	0.32

2. Push-lock speed controller installation instructions is the same as general one. Please refer to general type for specific content.

Inner structure

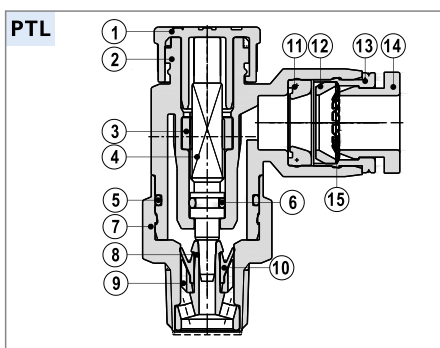

NO.	Name	Material	NO.	Name	Material
1	Adjusting cap	POM	9	Holder	PBT
2	Plastic body	PBT	10	O-ring	NBR
3	Locating ring	Aluminum alloy	11	O-ring	NBR
4	Throttling column	Aluminum alloy	12	Locating seat	POM
5	O-ring	NBR	13	Locating ring	Aluminum alloy
6	O-ring	NBR	14	Plastic interface	POM
7	Throttling body	Brass	15	Spring gasket	Stainless steel
8	Throttling sleeve	Aluminum alloy			

Dimensions

PTL Series

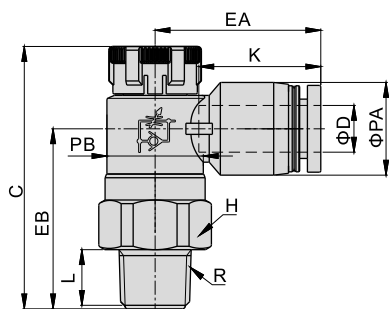

Model/Item [Note1]	ΦD	R	ΦPA	ΦPB	L	C		K	EA	EB	H	Weight (g)
						Pull	Push					
PTL601□	6	1/8"	12.5	13	8.5	36	34.5	16.5	22.5	23.5	14	12.5
PTL602□		1/4"	12.5	16.5	11	40.5	39	16.5	24	28	17	19.5
PTL603□		3/8"	12.5	19	12	44	42.5	16.5	25.5	31	19	28.5
PTL801□	8	1/8"	15	13	8.5	36	34.5	18.5	24.5	22.5	14	13
PTL802□		1/4"	15	16.5	11	40.5	39	18.5	26	27	17	20.5
PTL803□		3/8"	15	19	12	44	42.5	18.5	27	30	19	29
PTL804□	1/2"	15	24	15	52.5	51	18.5	29.5	37.5	24	49	
PTL1002□	10	1/4"	18	16.5	11	40.5	39	21	31	26	17	22
PTL1003□		3/8"	18	19	12	44	42.5	21	29	29	19	30.5
PTL1004□		1/2"	18	24	15	52.5	51	21	31.5	36.5	24	50.5
PTL1203□	12	3/8"	21	19	12	44	42.5	23	34.5	28	19	32.5
PTL1204□		1/2"	21	24	15	52.5	51	23	34	36	24	53

[Note1] "□" stands for A or B. A indicates meter-out type while B indicates meter-in type. The two types are with the same overall dimension.

Flowrate characteristic

Controlled flow rate

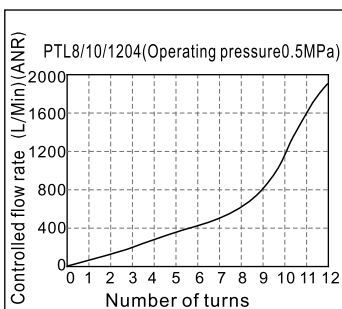
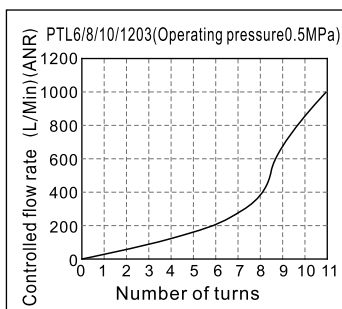
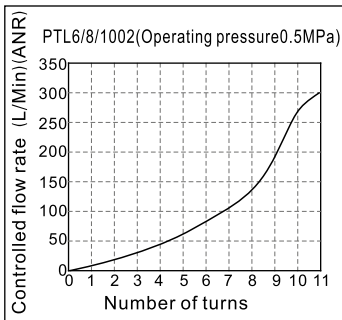
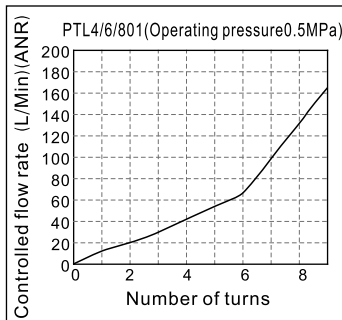
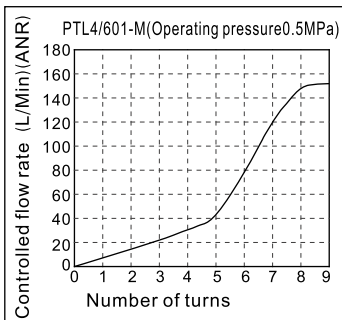
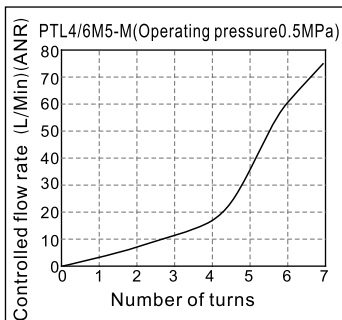

Free flow rate

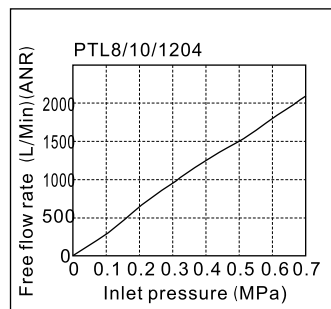
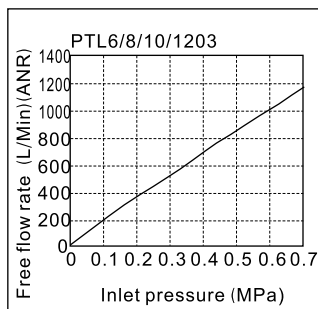
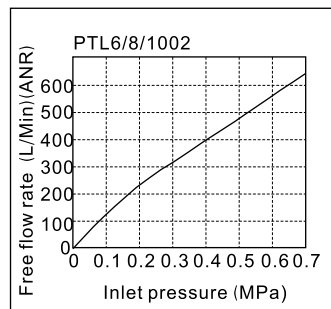
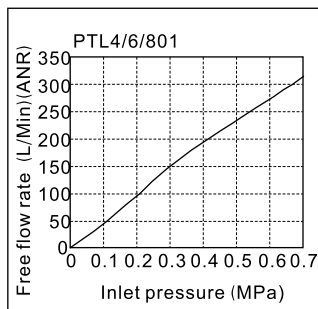
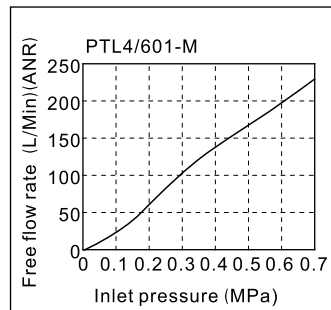
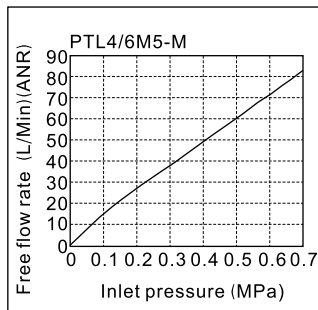

Specification

Model	PHV6	PHV8	PHV10	PHV12
Operating pressure range	0~10kgf/cm ² (0~1.0MPa)			
Negative pressure	-750mmHg(10Torr)			
Proof pressure	1.5MPa			
Ambient and fluid temperature (°C)	-20~70			
Applicable tubing	Soft nylon or polyurethane			
Color	Grey/black			



Symbol

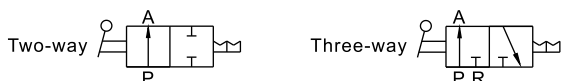

Product feature

1. PHV series product doesn't contain brass, so can be used for forbidding brass condition.
2. When the three-way valve is closed, the outlet pressure is released, which facilitates in commissioning and maintenance.
3. The finger valve has excellent flow characteristic and high sensitive uni-direction characteristic.

Ordering code

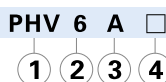

① Fitting type	② Port size	③ Valve specification	④ Standard color
PHV: Finger valve	6: Φ6mm	A: Three-way B: Two-way	Blank: Gray(Release button: Gray Body: Gray) D: Black(Release button: Black Body: Black)
	8: Φ8mm		
	10: Φ10mm		
	12: Φ12mm		

Diagram of finger valve in the open and closed states

Closed state

Valve is closed, when the angle between the arrow on knob and the arrow on valve body is 90 degree



Opened state

Valve is open, when the direction of the arrow on commutation knob is consistent with that on valve body.



When the three-way valve is closed, the outlet pressure is released, which facilitates in commissioning and maintenance. (as figure below)

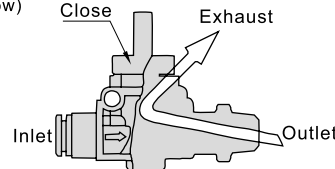

Inner structure

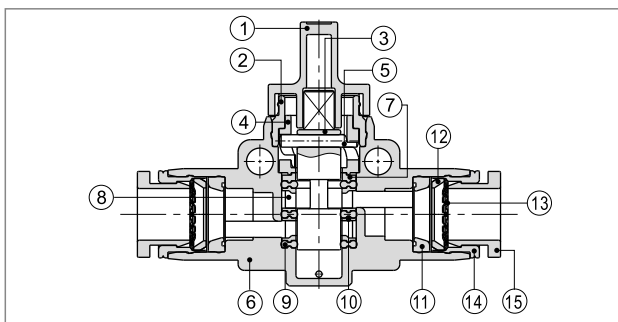

NO.	Name	Material	NO.	Name	Material
1	Knob	POM	9	Special shape O-ring	NBR
2	Fixing ring	Aluminum alloy	10	Spacer ring	Aluminum alloy
3	Spool	Aluminum alloy	11	Special shape O-ring	NBR
4	Cam groove block	POM	12	Locating seat	POM
5	Pin	Stainless steel	13	Spring gasket	Stainless steel
6	Plastic body	PBT	14	Locating ring	Aluminum alloy
7	Locating block	Aluminum alloy	15	Plastic interface	POM
8	Spacer	POM			

Dimensions

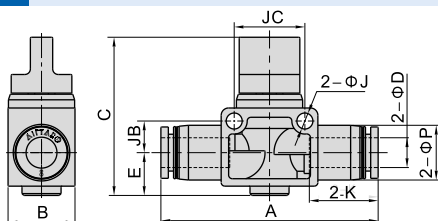

Model/Item	ΦD	A	B	C	ΦP	K	E	ΦJ	JB	JC	Weight(g)
PHV6□	6	51.5	17	40.5	12.5	16.5	10	4.3	8	18	14.3
PHV8□	8	58.5	18	42.5	15	18.5	11.5	4.3	8.5	19	17.5
PHV10□	10	66	21	42	18	21	11	4.3	11	24	25.1
PHV12□	12	71	22	46	21	23	13	4.3	11	24	31.4



Note: "□" indicates "A" or "B", "A" indicates three-way, and "B" indicates two-way.

The two kinds of valve have same dimensions.

Ordering code

PC 6 01 □ □ - S

① ② ③ ④ ⑤ ⑥

① Model	② Port size	③ Thread connection	④ Standard color	⑤ Thread type	⑥ Material	
PC: Male connector 	4: Φ 4mm 6: Φ 6mm 8: Φ 8mm	Thread connection: M5: M5X0.8 01: 1/8" 02: 1/4" 03: 3/8" 04: 1/2"	Adaptable port size: Φ 4, Φ 6 Φ 4, Φ 6 Φ 8, Φ 10 Φ 12	Standard color: Blank: Gray D: Black Specification: Release button: Gray Release button: Black	Blank: PT	S: Stainless steel 304
POC: Male connector 	10: Φ 10mm 12: Φ 12mm					

Specification

Operating pressure range	0~10kgf/cm ² (0~1.0MPa)
Negative pressure	-750mmHg(10Torr)
Proof pressure	1.5MPa
Ambient and fluid temperature (°C)	-20~70
Applicable tubing	Soft nylon or polyurethane
Color	Grey/black

Table for interface port and tube O.D.

Product series	Thread type	Port size				
		Φ 4	Φ 6	Φ 8	Φ 10	Φ 12
PC	M5	●	●			
	1/8"	●	●	●	●	●
	1/4"	●	●	●	●	●
	3/8"		●	●	●	●
	1/2"		●	●	●	●
POC	M5	●	●			
	1/8"	●	●	●	●	
	1/4"	●	●	●	●	●
	3/8"		●	●	●	●
	1/2"			●	●	●

Product feature

1. Body material is stainless steel, and all parts don't contain copper.
2. The threaded portion is covered with sealant and the M5 thread is attached with a sealing gasket to prevent air leakage over the connection thread portion.
3. Grey and black are optional for the release button.

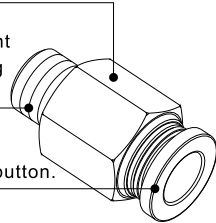

Inner structure

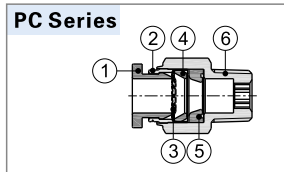

No.	Item	Material
1	Release button	POM
2	Guide	Aluminum alloy
3	Spring gasket	Stainless steel
4	Chuck	POM
5	O-ring	NBR
6	Body	Stainless steel 304

Dimensions

PC Series

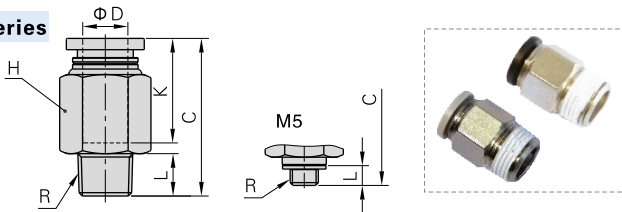

POC Series

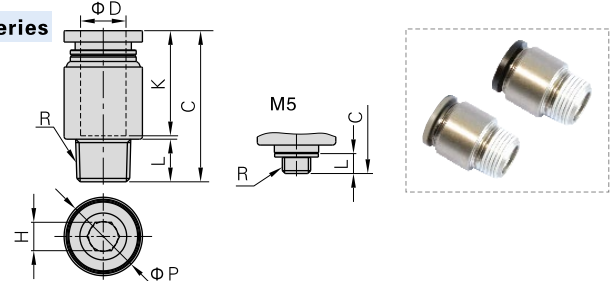

Model\Item	Φ D	R	L	C	K	H(Across flat)	Weight(g)
PC4M5	4	M5×0.8	3.5	19.5	14	9	6
PC401		1/8"	7.5	19.5	14	10	6.5
PC402		1/4"	10	19.5	14	14	12.5
PC6M5	6	M5×0.8	3.5	22.5	16.5	12	8
PC601		1/8"	7.5	22.0	18.5	12	7
PC602		1/4"	10	24.5	18.5	14	14.5
PC603		3/8"	11	22.5	18.5	17	22
PC604		1/2"	14	26.0	18.5	21	42
PC801	8	1/8"	7.5	28	18.5	14	12.5
PC802		1/4"	10	27	18.5	14	12
PC803		3/8"	11	23.5	18.5	17	19.5
PC804		1/2"	14	27	18.5	21	40
PC1001	10	1/8"	7.5	30	21	17	19
PC1002		1/4"	10	32.5	21	17	22
PC1003		3/8"	11	28	21	17	19
PC1004	12	1/2"	14	26.5	21	21	33
PC1201		1/8"	7.5	32.5	23	21	35.5
PC1202		1/4"	10	35	23	21	37.5
PC1203		3/8"	11	30.5	23	21	26.5
PC1204	1/2"	14	32.5	23	21	38.5	

Model\Item	Φ D	R	Φ P	L	C	K	H(Across flat)	Weight(g)	
POC4M5	4	M5×0.8	9	3.5	18.5	14	2.5	3.5	
POC401		1/8"	10	7.5	18	14	3	5	
POC402		1/4"	14	10	19.5	14	3	11.5	
POC6M5	6	M5×0.8	12	3.5	21.5	16.5	2.5	5.5	
POC601		1/8"	12	7.5	22.0	18.5	4	6	
POC602		1/4"	14	10	22.0	18.5	4	11	
POC801		8	1/8"	14	7.5	26.5	18	5	9
POC802			1/4"	14	10	25	18	6	9.5
POC803	3/8"		17	11	23.5	18	6	18	
POC1001	10	1/8"	17	7.5	30	21	5	15.5	
POC1002		1/4"	17	10	29	21	6	14.5	
POC1003		3/8"	17	11	28	21	8	17.5	
POC1004	12	1/2"	21	14	26.5	21	8	32.5	
POC1202		1/4"	21	10	34.5	23	6	30	
POC1203		3/8"	21	11	30	23	8	23	
POC1204		1/2"	21	14	32	23	8	34.5	

Ordering code

Same diameter type fittings

PL 6 01 - S

① ② ③ ④ ⑤ ⑥

① Model	② Port size	③ Thread connection	④ Standard color	⑤ Thread type	⑥ Material
PHW: Double universal male elbow 	PL: Male elbow 	M5: M5X0.8 01: 1/8" 02: 1/4" 03: 3/8" 04: 1/2"	Adaptable port size Φ4, Φ6 Blank: Gray D: Black	Standard color Specification Release button: Gray Adaptable model PCF PMF Release button: Gray Body: Gray Others Release button: Black PCF PMF Release button: Black Body: Black Others	Blank: PT S: Stainless steel 304
PHF: Universal female elbow 	PLL: Extended male elbow 				
PEB: Male branch tee 	PZB: Threaded cross 				
PED: Male run tee 	PH: Universal male elbow 				
PYB: Branch "Y" 					

Different diameter type fittings

PKD 6 - 4 01 - S

① ② ③ ④ ⑤ ⑥ ⑦

① Model	② Port size	③ Port size	④ Thread connection	⑤ Standard color	⑥ Thread type	⑦ Material
PKD: Male reducer triple branch 	6: Φ6mm 8: Φ8mm 10: Φ10mm	4: Φ4mm 6: Φ6mm 8: Φ8mm	01: 1/8" 02: 1/4" 03: 3/8"	Standard color Specification Blank: Gray Release button: Gray/Body: Gray D: Black Release button: Black/Body: Black	Blank: PT	S: Stainless steel 304

Specification

Operating pressure range	0~10kgf/cm ² (0~1.0MPa)
Negative pressure	-750mmHg(10Torr)
Proof pressure	1.5MPa
Ambient and fluid temperature (°C)	-20~70
Applicable tubing	Soft nylon or polyurethane
Color	Grey/black

Product feature

1. Stainless steel 304 material can be used for forbidding copper condition.
2. Variable models can be widely used in every kind of pneumatic systems.
3. High circulation performance: bear the same flow with the volume of the tubing inside diameter.
4. Connect tubing easily and conveniently. The tubing connection portion is safe and durable.
5. The threaded portion is covered with sealant and the M5 thread is attached with a sealing gasket to prevent air leakage over the connection thread portion.

Inner structure

No.	Item	Material
1	Release button	POM
2	Guide	Aluminum alloy
3	Spring gasket	Stainless steel
4	Chuck	POM
5	O-ring	NBR
6	Body	PBT
7	O-ring	NBR
8	Stud	SUS304

Table for interface port and tube O.D.

Product series	Thread type	Port size				
		Φ4	Φ6	Φ8	Φ10	Φ12
PL	M5	●	●			
	1/8"	●	●	●	●	●
	1/4"	●	●	●	●	●
	3/8"		●	●	●	●
	1/2"		●	●	●	●
PLL	M5	●	●			
	1/8"	●	●	●	●	
	1/4"	●	●	●	●	●
	3/8"		●	●	●	●
	1/2"		●	●	●	●
PEB PED PYB	M5	●	●			
	1/8"	●	●	●	●	
	1/4"	●	●	●	●	●
	3/8"		●	●	●	●
	1/2"		●	●	●	●
PH PHF	M5	●	●			
	1/8"	●	●	●		
	1/4"		●	●	●	
	3/8"		●	●	●	●
	1/2"		●	●	●	●
PHW	1/8"	●	●	●		
	1/4"		●	●	●	
	3/8"		●	●	●	●
PZB	1/8"		●	●		
	1/4"		●	●	●	
	3/8"		●	●	●	●
	1/2"		●	●	●	●

Product series	Thread type	Port size		
		Φ6-Φ4	Φ8-Φ6	Φ10-Φ8
PKD	1/8"	●		
	1/4"		●	
	3/8"			●

Dimensions

PL Series

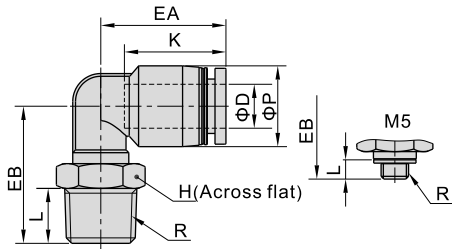

Model\Item	ΦD	R	ΦP	L	K	EA	EB	H	Weight(g)
PL4M5	4	M5×0.8	9	3.5	14	17	15	8	3
PL401		1/8"	9	7.5	14	17	18.5	10	4.5
PL402		1/4"	9	10	14	17	22.0	14	11
PL6M5	6	M5×0.8	12.5	3.5	17	20	17.0	8	4.5
PL601		1/8"	12.5	7.5	17	20	20.5	10	6
PL602		1/4"	12.5	10	17	20	24.0	14	12.5
PL603	8	3/8"	12.5	11	17	20	25.5	17	19
PL604		1/2"	12.5	14	17	20	30.0	21	33
PL801		1/8"	15	7.5	18.5	23	20.5	10	7
PL802	10	1/4"	15	10	18.5	23	25.0	14	12
PL803		3/8"	15	11	18.5	23	26.5	17	19.5
PL804		1/2"	15	14	18.5	23	31.0	21	33
PL1001	12	1/8"	18	7.5	21	25.5	25.0	17	15.5
PL1002		1/4"	18	10	21	25.5	27.0	17	18
PL1003		3/8"	18	11	21	25.5	28.0	17	20
PL1004	12	1/2"	18	14	21	25.5	32.5	21	34.5
PL1201		1/8"	21	7.5	23	28.5	26.5	17	18
PL1202		1/4"	21	10	23	28.5	28.5	17	20.5
PL1203	12	3/8"	21	11	23	29.5	33	17	24
PL1204		1/2"	21	14	23	29.5	34	21	34.5

PYB Series

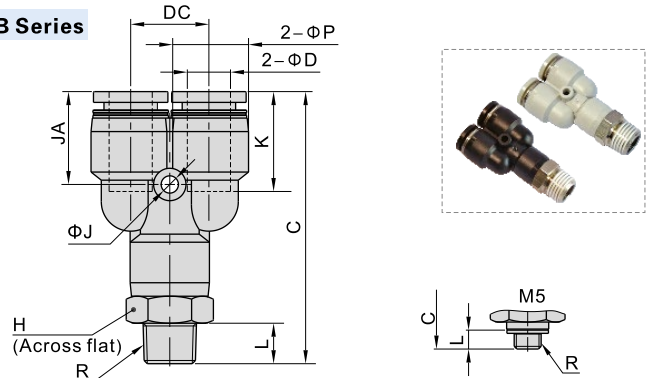

Model\Item	ΦD	R	ΦP	L	C	K	ΦJ	JA	DC	H	Weight(g)
PYB4M5	4	M5×0.8	9	3.5	35.5	14	3.2	13	10	9	6.5
PYB401		1/8"	9	7.5	39.5	14	3.2	13	10	10	8.5
PYB402		1/4"	9	10	42.5	14	3.2	13	10	14	10
PYB6M5	6	M5×0.8	12.5	3.5	40.5	16.5	3.2	15.5	12	12	10.5
PYB601		1/8"	12.5	7.5	44.5	16.5	3.2	15.5	12	12	13
PYB602		1/4"	12.5	10	47.5	16.5	3.2	15.5	12	14	17
PYB603	8	3/8"	12.5	11	49.0	16.5	3.2	15.5	12	17	23.5
PYB801		1/8"	15	7.5	50	18.5	3.2	17	14.5	14	19
PYB802		1/4"	15	10	52.5	18.5	3.2	17	14.5	14	21
PYB803	10	3/8"	15	11	54	18.5	3.2	17	14.5	17	26
PYB804		1/2"	15	14	58	18.5	3.2	17	14.5	21	38
PYB1001		1/8"	18	7.5	56.5	21	4.3	19.5	18	17	26
PYB1002	12	1/4"	18	10	59	21	4.3	19.5	18	17	28
PYB1003		3/8"	18	11	60	21	4.3	19.5	18	17	31
PYB1004		1/2"	18	14	64	21	4.3	19.5	18	21	42.5
PYB1202	12	1/4"	21	10	66	23	4.3	21	20.5	21	26.5
PYB1203		3/8"	21	11	67	23	4.3	21	20.5	21	49
PYB1204		1/2"	21	14	70	23	4.3	21	20.5	21	53.5

PED Series

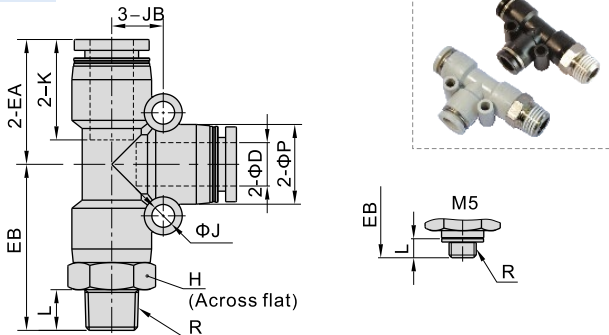

Model\Item	ΦD	R	ΦP	L	K	EA	EB	ΦJ	JB	H	Weight(g)
PED4M5	4	M5×0.8	9	3.5	14	17	21	3.2	6.5	9	6.5
PED401		1/8"	9	7.5	14	17	25	3.2	6.5	10	8.5
PED402		1/4"	9	10	14	17	28	3.2	6.5	14	14.5
PED6M5	6	M5×0.8	12.5	3.5	16.5	20	23.5	3.2	8	12	10.5
PED601		1/8"	12.5	7.5	16.5	20	27.5	3.2	8	12	13
PED602		1/4"	12.5	10	16.5	20	30.5	3.2	8	14	17.5
PED603	8	3/8"	12.5	11	16.5	20	32	3.2	8	17	23.5
PED801		1/8"	15	7.5	18.5	23	30.5	4.3	9.5	14	17.5
PED802		1/4"	15	10	18.5	23	33	4.3	9.5	14	20
PED803	10	3/8"	15	11	18.5	23	34.5	4.3	9.5	17	26.5
PED804		1/2"	15	14	18.5	23	38.5	4.3	9.5	21	38
PED1001		1/8"	18	7.5	21	26.5	34	4.3	11	17	25.5
PED1002	12	1/4"	18	10	21	26.5	36.5	4.3	11	17	27.5
PED1003		3/8"	18	11	21	26.5	37.5	4.3	11	17	30
PED1004		1/2"	18	14	21	26.5	41.5	4.3	11	21	42.5
PED1202	12	1/4"	21	10	23	30	41	4.3	13	21	47
PED1203		3/8"	21	11	23	30	42	4.3	13	21	48.5
PED1204		1/2"	21	14	23	30	45	4.3	13	21	54

PZB Series

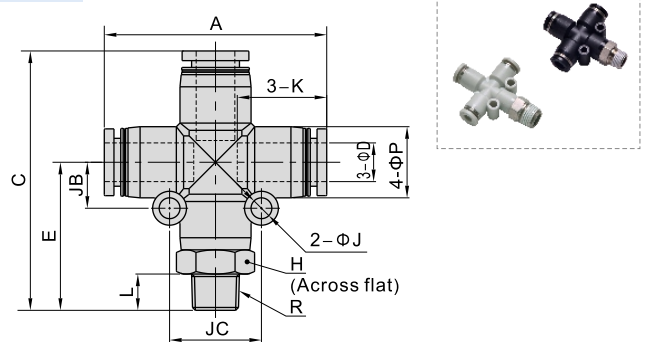

Model\Item	ΦD	R	L	A	E	C	ΦP	K	ΦJ	JB	JC	H	Weight(g)
PZB601	6	1/8"	7.5		27.5	47.5						12	14.5
PZB602		1/4"	10	39.5	30.5	50.5	12.5	16.5	3.2	8	16	14	19.5
PZB603		3/8"	11			32	52					17	25.5
PZB801	8	1/8"	7.5		30.5	53.5						14	20
PZB802		1/4"	10			33	56	15	18.5	4.3	9.5	19	22.5
PZB803		3/8"	11			34.5	57.5					17	28
PZB804	10	1/2"	14			38.5	61.5					21	40.5
PZB1002		1/4"	10			36.5	63					17	32
PZB1003		3/8"	11	52.5	37.5	64	18	21	4.3	11	22	17	35
PZB1004	12	1/2"	14			41.5	68					21	46.5
PZB1203		3/8"	11			42	72					21	53.5
PZB1204		1/2"	14	59.5	45	75	21	23	4.3	13	26	21	62

PLL Series

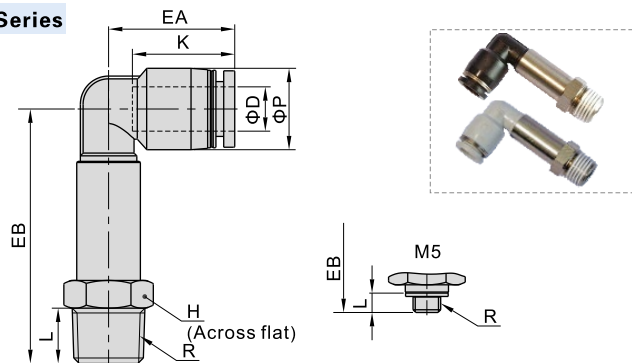

Model\Item	ΦD	R	ΦP	L	K	EA	EB	H	Weight(g)
PLL4M5	4	M5×0.8	9	3.5	14	17	32.5	8	8
PLL401		1/8"	9	7.5	14	17	35.5	10	11.5
PLL402		1/4"	9	10	14	17	38.5	14	15.5
PLL6M5	6	M5×0.8	12.5	3.5	17	20	34.5	8	9.5
PLL601		1/8"	12.5	7.5	17	20	37.5	10	12
PLL602		1/4"	12.5	10	17	20	40.5	14	16.5
PLL603	8	3/8"	12.5	11	17	20	43	17	21.5
PLL801		1/8"	15	7.5	18.5	23	43.5	12	15.5
PLL802		1/4"	15	10	18.5	23	45.5	14	21
PLL803	10	3/8"	15	11	18.5	23	48	17	25.5
PLL1001		1/8"	18	7.5	21	25.5	50.5	15	35
PLL1002		1/4"	18	10	21	25.5	53.5	15	37.5
PLL1003	12	3/8"	18	11	21	25.5	54.5	17	38
PLL1004		1/2"	18	14	21	25.5	59	21	44
PLL1202		1/4"	21	10	23	28.5	55.5	15	40
PLL1203	12	3/8"	21	11	23	29.5	60	17	51.5
PLL1204		1/2"	21	14	23	29.5	63	21	52.5

PHW Series

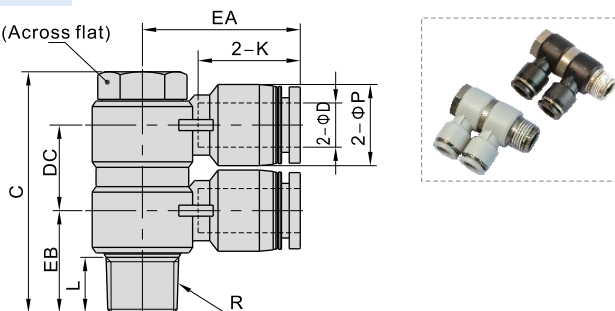

Model\Item	ΦD	R	ΦP	L	C	K	EA	EB	DC	H	Weight(g)
PHW401	4	1/8"	9	7.5	38	14	20.5	14.5	13	11	17.5
PHW601		1/8"	12.5	7.5	38	16.5	23.0	15	13	11	19.5
PHW602	6	1/4"	12.5	10	43.5	16.5	25.0	17.5	15.5	14	37.5
PHW603		3/8"	12.5	11	50	16.5	27.0	20	16.5	19	64
PHW801	8	1/8"	15	7.5	40.5	18.5	26.5	16.5	15.5	11	22.5
PHW802		1/4"	15	10	43.5	18.5	28.5	18.5	15.5	14	38
PHW803		3/8"	15	11	50	18.5	29.5	20	16.5	19	65
PHW804	10	1/2"	15	14	61	18.5	32	24.5	22	24	133.5
PHW1002		1/4"	18	10	46.5	21	31	20	18.5	14	44
PHW1003		3/8"	18	11	55	21	33	21	22	19	81.5
PHW1004	12	1/2"	18	14	61	21	35.5	25	22	24	127.5
PHW1203		3/8"	21	11	55	23	36	23	22	19	80.5
PHW1204	12	1/2"	21	14	61	23	38	26.5	22	24	137.5

PH Series

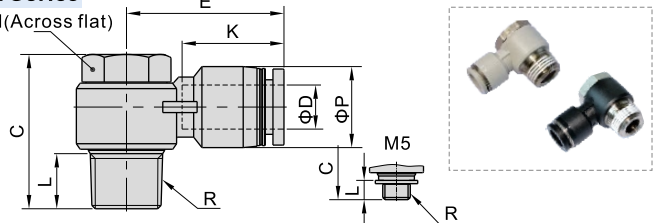

Model\Item	ΦD	R	ΦP	L	C	K	E	H	Weight(g)
PH4M5	4	M5×0.8	9	3.5	17	14	19	8	5.5
PH401		1/8"	9	7.5	25	14	20.5	11	12
PH6M5	6	M5×0.8	12.5	3.5	17	16.5	23.5	8	6.5
PH601		1/8"	12.5	7.5	25	16.5	23	11	13
PH602	8	1/4"	12.5	10	28	16.5	25	14	23.5
PH603		3/8"	12.5	11	33	16.5	27	19	46.5
PH801		1/8"	15	7.5	25	18.5	26.5	11	14
PH802	10	1/4"	15	10	28	18.5	28.5	14	24.5
PH803		3/8"	15	11	33	18.5	29.5	19	45.5
PH804	12	1/2"	15	14	39	18.5	32	24	82
PH1002		1/4"	18	10	28	21	31	14	26
PH1003		3/8"	18	11	33	21	33	19	47.5
PH1004	12	1/2"	18	14	39	21	35.5	24	81.5
PH1203		3/8"	21	11	33	23	36	19	49.5
PH1204	12	1/2"	21	14	39	23	38	24	86

PHF Series

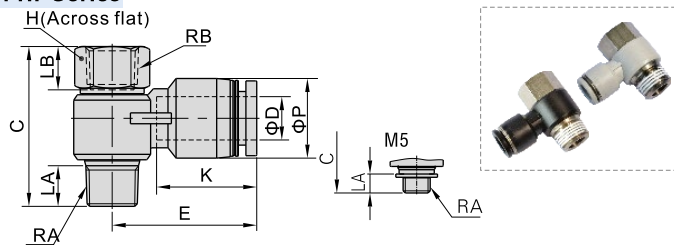

Model\Item	ΦD	RA	RB	ΦP	LA	LB	C	K	E	H	Weight(g)
PHF4M5	4	M5×0.8	M5×0.8	9	3.5	6	20	14	19	8	6
PHF401		1/8"	1/8"	9	7.5	8	29.5	14	20.5	12	12
PHF6M5	6	M5×0.8	M5×0.8	12.5	3.5	6	20	16.5	23.5	8	7
PHF601		1/8"	1/8"	12.5	7.5	8	29.5	16.5	23	12	13
PHF602	8	1/4"	1/4"	12.5	10	11	35	16.5	25	17	28
PHF603		3/8"	3/8"	12.5	11	12	40	16.5	27	19	41
PHF801		1/8"	1/8"	15	7.5	8	29.5	18.5	26.5	12	14
PHF802	10	1/4"	1/4"	15	10	11	35	18.5	28.5	17	28.5
PHF803		3/8"	3/8"	15	11	12	40	18.5	29.5	19	41.5
PHF804	12	1/2"	1/2"	15	14	13.5	47.5	18.5	32	24	78
PHF1002		1/4"	1/4"	18	10	11	35	21	31	17	30
PHF1003		3/8"	3/8"	18	11	12	40	21	33	19	43
PHF1004	12	1/2"	1/2"	18	14	13.5	47.5	21	35.5	24	79.5
PHF1203		3/8"	3/8"	21	11	12	40	23	36	19	45
PHF1204	12	1/2"	1/2"	21	14	13.5	47.5	23	38	24	83

PKD Series

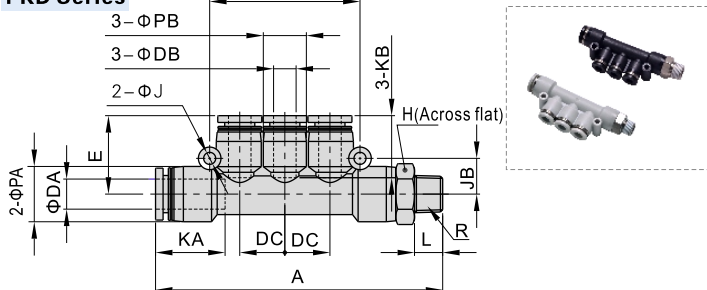

Model\Item	ΦDA	ΦDB	R	L	A	ΦPA	ΦPB	KA
PKD6-401	6	4	1/8"	7.5	66.5	12.5	9	16.5
PKD8-602	8	6	1/4"	10	79	15	12.5	18.5
PKD10-803	10	8	3/8"	11	91.5	18	15	21

Model\Item	KB	ΦJ	JB	JC	DC	E	H	Weight(g)
PKD6-401	14	3.2	8	34	10	17.5	12	15
PKD8-602	16.5	3.2	9.5	40	12	21	14	25.5
PKD10-803	18.5	4.3	11	48	14.5	24	17	36.5

PEB Series

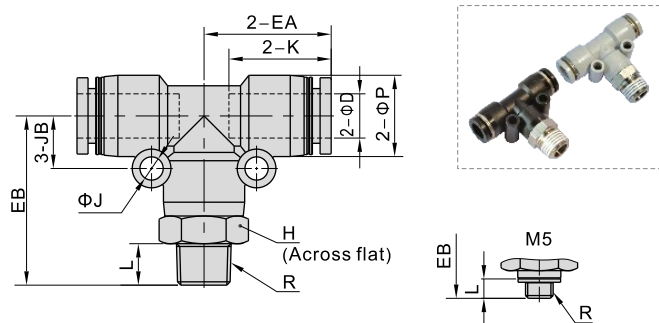



Model/Item	φD	R	φP	L	K	EA	EB	φJ	JB	H	Weight(g)
PEB4M5		M5×0.8	9	3.5	14	17	21	3.2	6.5	9	6.5
PEB401	4	1/8"	9	7.5	14	17	25	3.2	6.5	10	8.5
PEB402		1/4"	9	10	14	17	28	3.2	6.5	14	14.5
PEB6M5		M5×0.8	12.5	3.5	16.5	20	23.5	3.2	8	12	10.5
PEB601	6	1/8"	12.5	7.5	16.5	20	27.5	3.2	8	12	13
PEB602		1/4"	12.5	10	16.5	20	30.5	3.2	8	14	17.5
PEB603		3/8"	12.5	11	16.5	20	32	3.2	8	17	23.5
PEB801		1/8"	15	7.5	18.5	23	30.5	4.3	9.5	14	17.5
PEB802	8	1/4"	15	10	18.5	23	33	4.3	9.5	14	20
PEB803		3/8"	15	11	18.5	23	34.5	4.3	9.5	17	26.5
PEB804		1/2"	15	14	18.5	23	38.5	4.3	9.5	21	38
PEB1001		1/8"	18	7.5	21	26.5	34	4.3	11	17	25.5
PEB1002	10	1/4"	18	10	21	26.5	36.5	4.3	11	17	27.5
PEB1003		3/8"	18	11	21	26.5	37.5	4.3	11	17	30
PEB1004		1/2"	18	14	21	26.5	41.5	4.3	11	21	42.5
PEB1202		1/4"	21	10	23	30	41	4.3	13	21	47
PEB1203	12	3/8"	21	11	23	30	42	4.3	13	21	48.5
PEB1204		1/2"	21	14	23	30	45	4.3	13	21	54

Ordering code

BB 01 01 □ - S

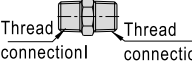
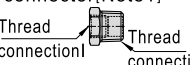
① ② ③ ④ ⑤

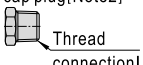
① Model	② Thread connection I	③ Thread connection II	④ Thread type	⑤ Material			
BB: Male connector 	BD: Male & female connector[Note1] 	BU: Double female connector 	BZ: Hexagon head cap plug[Note2] 	01: 1/8" 02: 1/4" 03: 3/8" 04: 1/2"	01: 1/8" 02: 1/4" 03: 3/8" 04: 1/2"	Blank: PT	S: SUS304

[Note1] For BD series, Thread I is Female thread, Thread II is male thread; [Note2] For BZ series, no thread II and thread I is male thread.

Specification

Operating pressure range	0~10kgf/cm ² (0~1.0MPa)
Negative pressure	-750mmHg(10Torr)
Proof pressure	3.0MPa
Ambient and fluid temperature (°C)	0~150

Configuration table of tubing thread

Product series	Thread connection I	Thread connection II			
		01	02	03	04
BB	01	●	●	●	●
	02		●	●	●
	03			●	●
	04				●
BD	01		●	●	●
	02			●	●
	03				●
	04				
BU	01	●			
	02		●		
	03			●	
	04				●
Product series	Thread connection				
	01	02	03	04	
BZ	●	●	●	●	

Product feature

1. Variable models can be widely used in every kind of pneumatic systems.
2. High circulation performance bear the same flow with the volume of the tube inner diameter.
3. Metal fittings can be used in high temperature environment.

Dimensions

BB Series

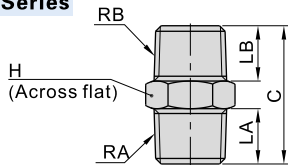

Model\Item	RA	RB	LA	LB	C	H	Weight(g)
BB0101	1/8"	1/8"	7.5	7.5	19.5	10	6
BB0102	1/4"	1/8"	10	7.5	22.5	14	11
BB0103	3/8"	1/8"	11	7.5	24	17	17
BB0202	1/4"	1/4"	10	10	25	14	13.5
BB0203	3/8"	1/4"	11	10	26.5	17	19
BB0204	1/2"	1/4"	14	10	30	21	31.5
BB0303	3/8"	3/8"	11	11	27.5	17	21.5
BB0304	1/2"	3/8"	14	11	31	21	33
BB0404	1/2"	1/2"	14	14	34	21	39.5

BD Series

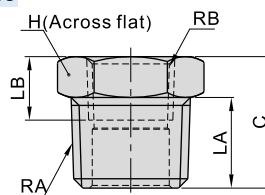

Model\Item	RA	RB	LA	LB	C	H	Weight(g)
BD0102	1/4"	1/8"	10	8	14.5	14	8
BD0103	3/8"	1/8"	11	8	16	17	15.5
BD0104	1/2"	1/8"	14	8	19.5	21	31
BD0203	3/8"	1/4"	11	11	16	17	11.5
BD0204	1/2"	1/4"	14	11	19.5	21	28
BD0304	1/2"	3/8"	14	12	19.5	21	20.5

BU Series

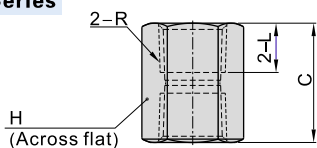

Model\Item	R	L	C	H	Weight(g)
BU0101	1/8"	8	17	12	8
BU0202	1/4"	11	23	17	23.5
BU0303	3/8"	12	25	21	36.5
BU0404	1/2"	13.5	28	24	42.5

BZ Series

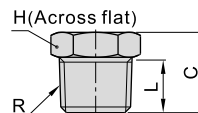

Model\Item	R	L	C	H	Weight(g)
BZ01	1/8"	7.5	11	10	4
BZ02	1/4"	10	14.5	14	10
BZ03	3/8"	11	16	17	16.5
BZ04	1/2"	14	19.5	21	30

Ordering code

BKC 06 04 - 01 □ - S

① ② ③ ④ ⑤ ⑥

① Model	② Tubing outer diameter	③ Tubing inner diameter	④ Thread connection	⑤ Thread type	⑥ Material
BKC: Straight locknut connector 	04: Φ4mm 06: Φ6mm 08: Φ8mm 10: Φ10mm 12: Φ12mm	25: Φ2.5mm 04: Φ4mm 05: Φ5mm 06: Φ6mm 65: Φ6.5mm 75: Φ7.5mm 08: Φ8mm 09: Φ9mm	M3: M3X0.5 M5: M5X0.8 01: 1/8" 02: 1/4" 03: 3/8" 04: 1/2"	Blank: PT	S: SUS304

Note: When using the tubing Φ8×Φ5.5, the straight lock nut connector of BKC0806 can be used.

Specification

Operating pressure range	0~10kgf/cm ² (0~1.0MPa)
Negative pressure	-750mmHg(10Torr)
Proof pressure	3.0MPa
Ambient and fluid temperature (°C)	0~150

Note: The temperature resistance level of the tubing should be confirmed first when used in high temperature environments.

Product feature

- Variable models can be widely used in every kind of pneumatic systems.
- High circulation performance bear the same flow with the volume of the tube innerdiameter.
- Metal fittings can be used in high temperature environments.

Configuration table of tubing and tubing thread

Product series	Tubing outer diameter	Tubing inner diameter	Thread connection					
			M3	M5	01	02	03	04
BKC	04	25	●	●	●			
	06	04			●	●	●	
	08	05			●	●	●	
		06			●	●	●	
	10	65				●	●	●
		75					●	●
	12	08				●	●	●
		09				●	●	●

Dimensions

BKC Series

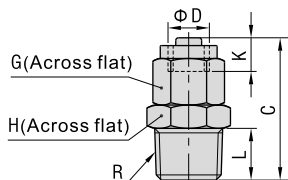

Model\Item	Tubing diameter ΦD		R	L	C	K	G	H	Weight(g)	Model\Item	Tubing diameter ΦD		R	L	C	K	G	H	Weight(g)			
	O.D	I.D									O.D	I.D										
BKC0425-M3	4	2.5	M3x0.5	3	17	5	8	8	4	BKC1065-02	10	6.5	1/4"	10	30	7.5	15	15	22			
BKC0425-M5				M5x0.8	3.5			17.5	8	4.5				BKC1065-03	11			31.5	17	26.5		
BKC0425-01				1/8"	7.5			20.5	10	6.5				BKC1065-04	14			35.5	21	40.5		
BKC0604-01	1/8"	7.5	22	10	9	BKC1075-02	1/2"	14	30	15				22								
BKC0604-02	1/4"	10	25.5	10	14	14.5	BKC1075-03	1/4"	10	30				17	26.5							
BKC0604-03	3/8"	11	27	17	20.5	BKC1075-04	3/8"	11	31.5	21		40										
BKC0805-01	6	4	1/8"	7.5	24	5.5	10	12	11.5	BKC1208-02		12	8	1/4"	10	30	7.5	17	17	28		
BKC0805-02				1/4"	10			27.5	14	16					BKC1208-03	3/8"			11	31.5	17	29.5
BKC0805-03				3/8"	11			29	17	21.5					BKC1208-04	1/2"			14	35.5	21	42.5
BKC0806-01				1/8"	7.5			24	12	12					BKC1209-02	1/4"			10	30	17	28
BKC0806-02				1/4"	10			27.5	14	15.5	BKC1209-03				3/8"	11			31.5	17	29	
BKC0806-03	3/8"	11	29	17	21.5	BKC1209-04	1/2"	14	35.5	21	42.5											

Installation and application

- Method of inserting or removal a tubing
 - Inserting a tubing
Place the locking cap over the tubing, and insert the tubing into the body, then tighten the locking cap. (As figure 1)
 - Removing a tubing
Loosen the locking cap first, then remove the tubing. (As figure 2)
- Method of tightening the connector thread
Tighten the connector with a hex wrench, as shown right.

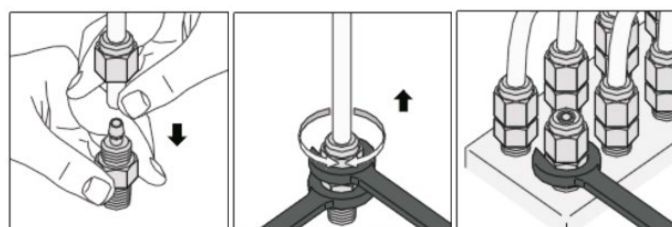

Figure 1

Figure 2

Figure 3

Ordering code

BSL 01 - S

① ② ③

① Silencer Type	② Thread connection	③ Material
BSL: Universal silencer BSLM: Mini Silencer BESL: Throttling silencer	M5: M5X0.8 01: 1/8" 02: 1/4" 03: 3/8" 04: 1/2"	S: SUS304

Product feature

1. Stainless steel 304 material can be used in prohibiting copper condition.
2. This silencers have excellent noise silencing performance.
3. The installation of the silencer is simple and convenient, and the connecting portion is reliable and durable.
4. It is easy to adjust the exhaust flow of the throttling type silencer.

Configuration table of tubing thread

Product series	Thread connection				
	M5	01	02	03	04
BSL	●	●	●	●	●
BSLM	●	●	●	●	●
BESL		●	●	●	●

Specification

Model	BSLM5	BSL01	BSL02	BSL03	BSL04	BSLMM5	BSLM01	BSLM02	BSLM03	BSLM04	BESL01	BESL02	BESL03	BESL04
Thread connection	M5×0.8	1/8"	1/4"	3/8"	1/2"	M5×0.8	1/8"	1/4"	3/8"	1/2"	1/8"	1/4"	3/8"	1/2"
Silencing effect(dB)(0.5MPa)	15	20	20	20	20	15	20	20	20	20	20	20	20	20
Operating pressure	0~10kgf/cm ² (0~1.0MPa)													
Negative pressure	-750mmHg(10Torr)													
Proof pressure	1.5MPa													
Temperature range	-20~70℃													

Inner structure

BSL Series

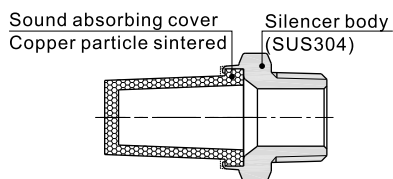

BESL Series

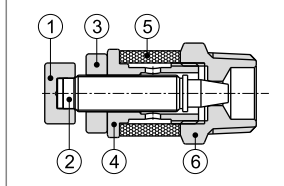

NO.	Name	Material
1	Adjusting cap	Aluminum alloy
2	Throttling column	Aluminum alloy
3	Locking cap	Aluminum alloy
4	Locking ring	Aluminum alloy
5	Silencer ring	Copper particle sintered
6	Silencer body	SUS304

Flowrate characteristic

BSL Series

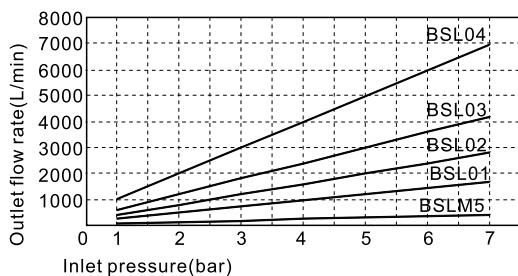

BSLM Series

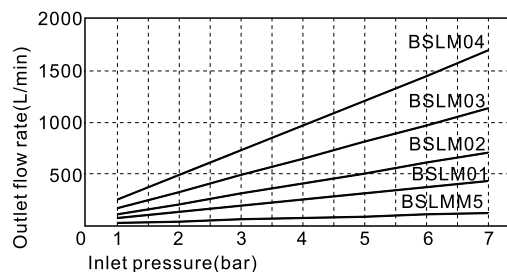

Flowrate characteristic

BESL Series (Inlet pressure and outlet flow rate)

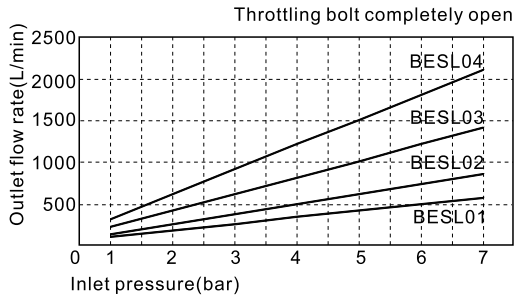

BESL Series

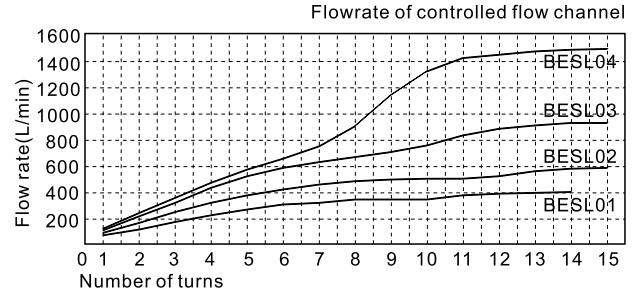

Dimensions

BSL Series

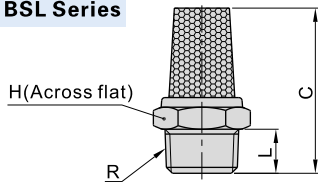

Model\Item	R	L	C	H	Weight(g)
BSLM5	M5×0.8	3.5	19.5	8	2.5
BSL01	1/8"	6	24	12	7
BSL02	1/4"	8	30	15	14
BSL03	3/8"	9	38.5	19	24.5
BSL04	1/2"	10.5	46	22	37.5

BSLM Series

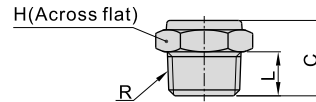

Model\Item	R	L	C	H	Weight(g)
BSLMM5	M5×0.8	3.5	9.5	8	2.5
BSLM01	1/8"	6	11	12	5
BSLM02	1/4"	8	13.5	15	9
BSLM03	3/8"	9	15.5	19	15
BSLM04	1/2"	10.5	19	22	25.5

BESL Series

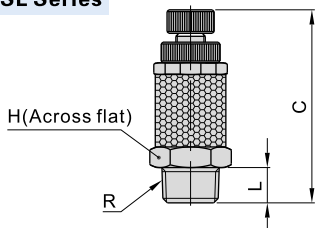



Model\Item	R	L	C		H	Weight(g)
			max	min		
BESL01	1/8"	6	40.5	33	12	11.5
BESL02	1/4"	8	42.5	35	14	17
BESL03	3/8"	9	49	41.5	17	30
BESL04	1/2"	10.5	59.5	52	24	66

Ordering code

PSL 6 01 A □ □ - S

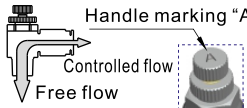
① ② ③ ④ ⑤ ⑥ ⑦

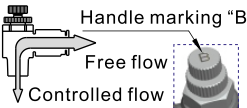
① Model	② Port size	③ Thread connection		④ Control method	⑤ Standard color		⑥ Thread type	⑦ Material
PSL: Speed controller	4: Φ4mm 6: Φ6mm 8: Φ8mm 10: Φ10mm 12: Φ12mm	Thread	Adaptable port size	A: Meter-out	Standard color	Specification	Blank: PT	S: SUS304
		M5: M5X0.8	Φ4, Φ6		Handle marking "A" Controlled flow Free flow	Blank: Gray		
PSS: Universal speed controller	4: Φ4mm 6: Φ6mm 8: Φ8mm 10: Φ10mm 12: Φ12mm	01: 1/8" 02: 1/4" 03: 3/8" 04: 1/2"	Φ4, Φ6 Φ8, Φ10 Φ12	B: Meter-in	D: Black	Release button: Black Body: Black		
					Handle marking "B" Free flow Controlled flow			

PSA 6 □ - S

① ② ③ ④

① Model	② Port size	③ Standard color		④ Material
PSA: Straight speed controller	4: Φ4mm 6: Φ6mm 8: Φ8mm 10: Φ10mm 12: Φ12mm	Standard color	Specification	S: SUS304
		Blank: Gray	Release button: Gray Body: Gray	
		D: Black	Release button: Black Body: Black	

Product feature

1. Stainless steel 304 material can be used in prohibiting copper condition.
2. The silencer is small size, and light weight with small installation space.
3. Excellent flow characteristics, high sensitivity and easy to adjust.
4. The silencer brass body adopts a special nickel-plating process, which has good corrosion resistance and anti-pollution property.
5. Anti-drop structure is designed on the regulating rod.
6. The sealant being coated on threaded portion can ensure no leakage of the threaded connection part.
7. The inserting direction of universal speed controller can be adjusted in 360°.

Specification

Operating pressure range	0~10kgf/cm ² (0~1.0MPa)
Negative pressure	-750mmHg(10Torr)
Proof pressure	1.5MPa
Ambient and fluid temperature (°C)	-20~70
Applicable tubing	Soft nylon or polyurethane
Color	Grey/black

Table for interface port and tube O.D.

Product series	Thread type	Port size				
		Φ4	Φ6	Φ8	Φ10	Φ12
PSA	-	●	●	●	●	●
	M5	●	●	●	●	●
PSL	1/8"	●	●	●	●	●
	1/4"		●	●	●	●
	3/8"		●	●	●	●
PSS	1/2"			●	●	●
	M5	●				
	1/8"		●	●	●	●
	1/4"		●	●	●	●
	3/8"				●	●
	1/2"					●

Symbol

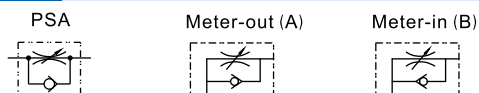

Inner structure

PSA Series

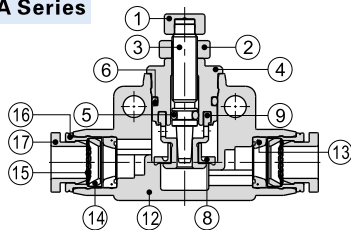

PSL Series

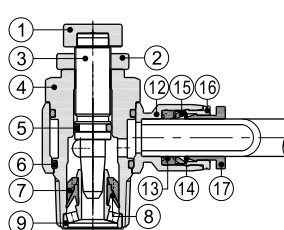

PSS Series

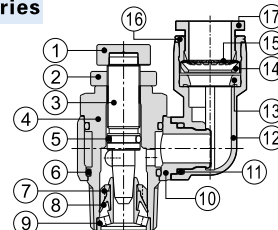

NO.	Name	Material	NO.	Name	Material	NO.	Name	Material
1	Adjusting cap	Aluminum alloy	7	Holder	PBT	13	O-ring	NBR
2	Locking cap	Aluminum alloy	8	O-ring	NBR	14	Locating seat	POM
3	Throttling column	SUS304	9	Throttling sleeve	SUS304	15	Spring gasket	Stainless steel
4	Throttling body	Aluminum alloy/SUS304	10	Plastic body	PBT	16	Locating ring	Aluminum alloy
5	O-ring	NBR	11	O-ring	NBR	17	Plastic interface	POM
6	O-ring	NBR	12	Plastic body	PBT			

Dimensions

PSL Series

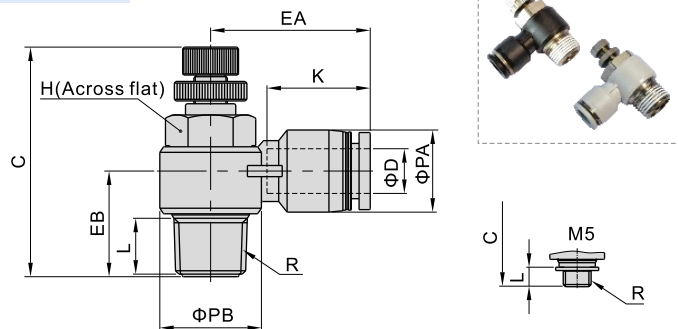

PSS Series

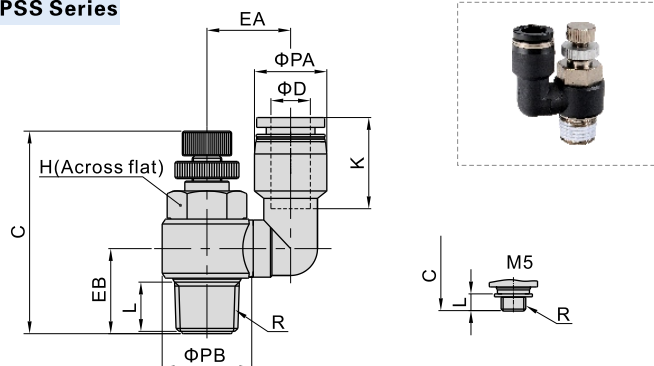

Model/Item [Note1]	ΦD	R	ΦPA	ΦPB	L	C		K	EA	EB	H	Weight (g)
						max	min					
PSL4M5□	4	M5×0.8	9	10	3.5	30	27.5	14	19	9.5	8	6
PSL401□		1/8"	9	14	7.5	41.5	35	14	20.5	15	11	15.5
PSL6M5□	6	M5×0.8	12.5	10	3.5	30	27.5	16.5	23.5	11.5	8	7.5
PSL601□		1/8"	12.5	14	7.5	41.5	35	16.5	23	15.5	11	16.5
PSL602□	6	1/4"	12.5	18	10	47.5	41	16.5	25	18	14	30
PSL603□		3/8"	12.5	22.5	11	52.5	45.5	16.5	27	20	19	55
PSL801□	8	1/8"	15	14	7.5	41.5	35	18.5	26.5	16.5	11	17
PSL802□		1/4"	15	18	10	47.5	41	18.5	28.5	19	14	31
PSL803□		3/8"	15	22.5	11	52.5	45.5	18.5	29.5	20	19	55.5
PSL804□		1/2"	15	28	14	58.5	51.5	18.5	32	25	24	89
PSL1002□	10	1/4"	18	18	10	47.5	41	21	31	20.5	14	32.5
PSL1003□		3/8"	18	22.5	11	52.5	45.5	21	33	21.5	19	57.5
PSL1004□		1/2"	18	28	14	58.5	51.5	21	35.5	25.5	24	90.5
PSL1203□		12	3/8"	21	22.5	11	52.5	45.5	23	36	23.5	19
PSL1204□	1/2"		21	28	14	58.5	51.5	23	38	27	24	92.5

[Note1] "□" stands for A or B. A indicates meter-out type while B indicates meter-in type. The two types are with the same overall dimension.

Model/Item [Note1]	ΦD	R	ΦPA	ΦPB	L	C		K	EA	EB	H	Weight (g)
						max	min					
PSS4M5□	4	M5×0.8	9	10	3.5	30	27.5	14	12.5	9.5	8	7.5
PSS601□		1/8"	12.5	14	7.5	41.5	35	17	17	15	11	18
PSS602□	6	1/4"	12.5	18	10	47.5	41	17	19	17.5	14	32.5
PSS801□		1/8"	15	14	7.5	41.5	35	18.5	17	15	11	19
PSS802□	8	1/4"	15	18	10	47.5	41	18.5	19	17.5	14	37.5
PSS1002□		1/4"	18	18	10	47.5	41	21	20.5	17.5	14	35
PSS1003□	10	3/8"	18	22.5	11	52.5	45.5	21	24	20	19	61.5
PSS1203□		3/8"	21	22.5	11	52.5	45.5	23	25.5	20	19	65
PSS1204□	12	1/2"	21	28	14	58.5	51.5	23	28	25	24	98.5

[Note1] "□" stands for A or B. A indicates meter-out type while B indicates meter-in type. The two types are with the same overall dimension.

PSA Series

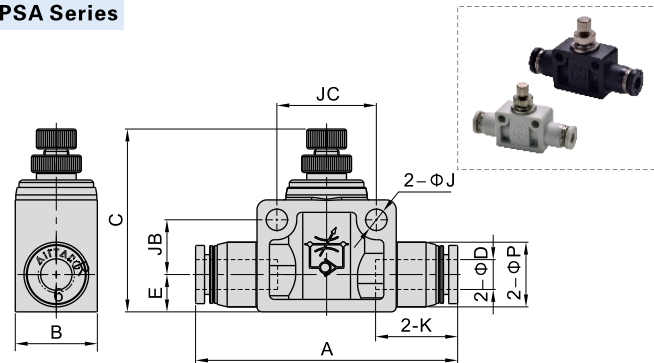

Model/Item	ΦD	A	B	C		ΦP	E	K	ΦJ	JB	JC	Weight (g)
				max	min							
PSA4	4	41	11	29	26.5	9.5	7	14	3.2	6	14	7.5
PSA6	6	52.5	16.5	43.5	36.5	13	7.5	16.5	4.3	11	20	18
PSA8	8	59.5	16.5	47	40	15	8.5	18.5	4.3	11	22	23
PSA10	10	69	21	53.5	46.5	18	10.5	21	4.3	14.5	26	41.5
PSA12	12	78.5	26	58.5	51	21.5	12	23	4.3	17.5	32	66

Flowrate characteristic

Controlled flow rate

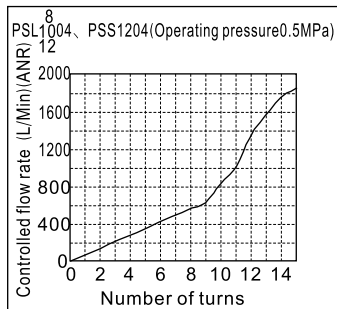
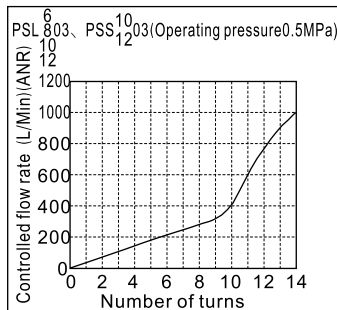
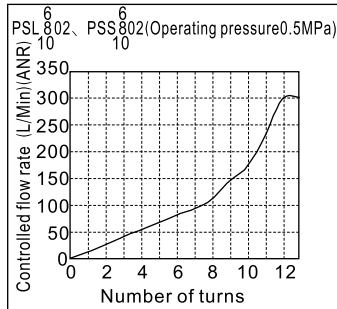
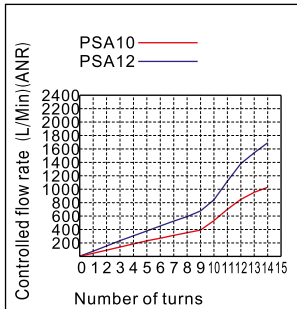
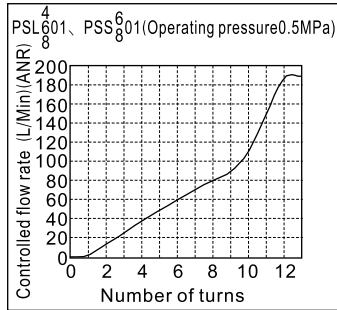
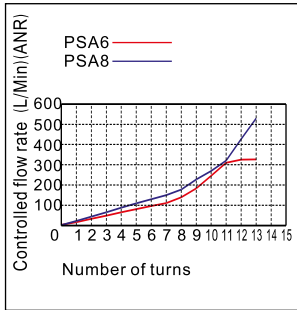
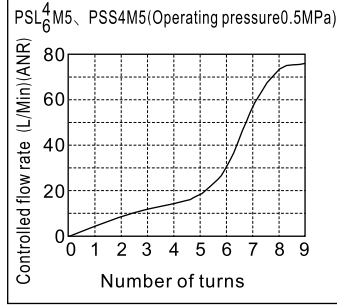
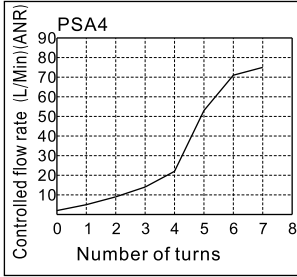



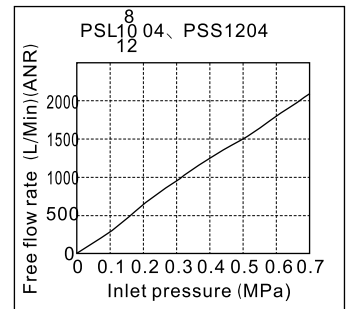
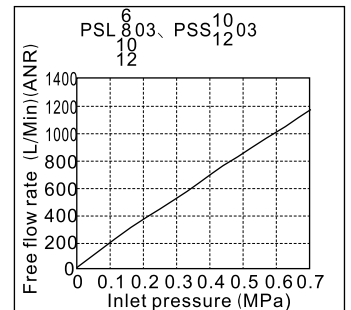
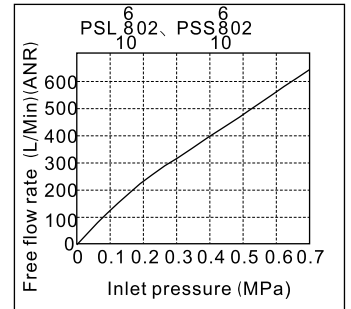
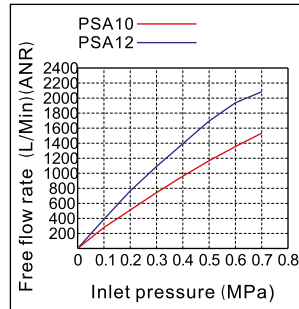
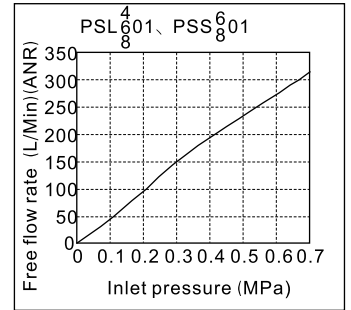
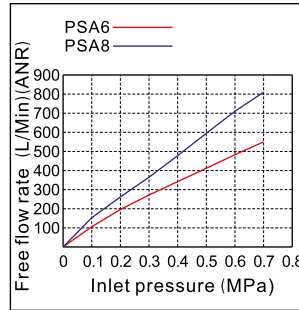
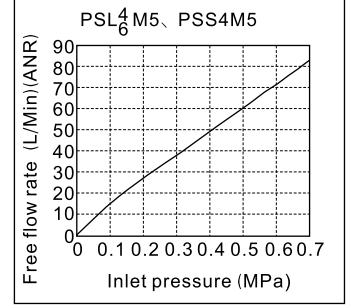
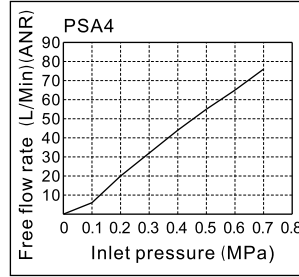

Free flow rate

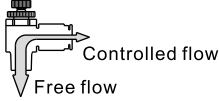

Selection, Installation and Operation

Selection

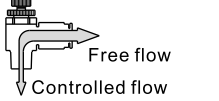
- The speed controller has meter-out type and meter-in type:

	Working principle	Product identification
 <p>Controlled flow Free flow</p>	A: Meter-out 1. The air flow is controlled from the threaded end to tubing connection end. 2. The air flow is free from the tubing connection end to the threaded end.	Handle marking "A" 
 <p>Free flow Controlled flow</p>	B: Meter-in 1. The air flow is free from the threaded end to tubing connection end. 2. The air flow is controlled from the tubing connection end to the threaded end.	Handle marking "B" 

- Select the different control method according to the actual requirement. The meter-out type is the first priority.

- 2.1. The application example of the meter-out speed controller
- 2.2. The application example of the meter-in speed controller

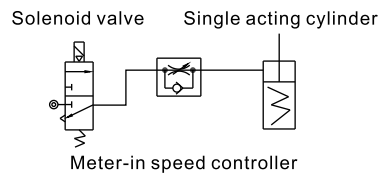
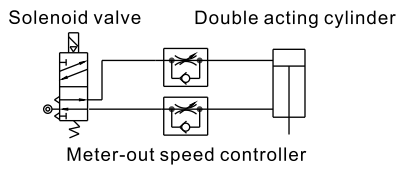

Installation

- Installation and removal of tubing:

- 1.1. Installation of tubing

Grasp the tubing and slowly push it into the fitting until it comes to a stop. The tubing will be locked by the spring gasket.

- 1.2. Removal of tubing

Push the release button to open the spring gasket so that the tubing can be released.

Note: When remove the tubing, make sure the pressure in the tubing is Zero.

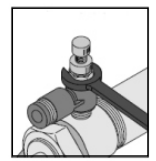
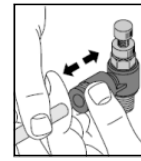
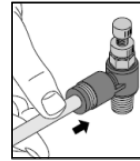

2. Mounting of the speed controller

Mount the speed controller into the inlet and outlet port of the cylinder with a wrench.

Note: Please refer to the fittings for the tightening torque and thread screw-in depth.

Operation

1. Adjustment of the cylinder speed

1.1. Make sure the speed controller is turned off before applying air pressure. The cylinder may fly out due to the high speed if the air is inlet when the speed controller is turned on.

1.2. Adjust the speed by opening the needle slowly from the fully closed state. When a needle valve is turned clockwise, the air flow through is reduced and the actuator speed decreases. When a needle valve is turned counter-clockwise, the air flow through is increased and the actuator speed increases.

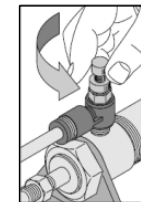
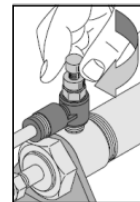



2. Operation of the speed controller

2.1. Do not use tools such as pliers to rotate the handle. Do not apply excessive force or shock when the needle is at the place of top or bottom. It can cause damage or air leakage.

2.2. A certain amount of leakage is allowed in the closed state of the speed controller. It is not designed for the use as stop valve with zero air leakage.

Ordering code

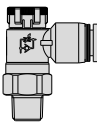
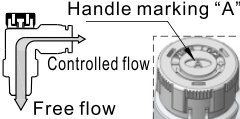
PTL 6 M5 A □ □ -M S
① ② ③ ④ ⑤ ⑥ ⑦ ⑧

① Model	② Port size	③ Thread connection	④ Control method	⑤ Standard color	⑥ Thread type	⑦ Style	⑧ Material
PTL: Speed controller (Push lock) 	4: Φ4mm 6: Φ6mm	M5: M5X0.8 01: 1/8"	A: Meter-out  Handle marking "A" Controlled flow Free flow	Standard color Specification Blank: Gray Release button: Gray Body: Gray	Blank: PT	M: Mini type	S: SUS304
			B: Meter-in  Handle marking "B" Free flow Controlled flow	D: Black Release button: Black Body: Black			

Specification

Operating pressure range	0~10kgf/cm²(0~1.0MPa)
Negative pressure	-750mmHg(10Torr)
Proof pressure	1.5MPa
Ambient and fluid temperature (°C)	-20~70
Applicable tubing	Soft nylon or polyurethane
Color	Grey/black

Symbol

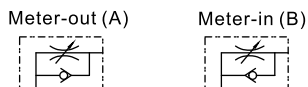

Selection, Installation and Operation

- The rotation torque of the push-lock speed controller cap should not be too large to avoid damage. It is recommended to use the torque below.

Thread size	Recommended torque(N.m)
M5	0.05
1/8"	0.08

- Push-lock speed controller installation instructions is the same as general one. Please refer to general type for specific content.

Dimensions

PTL Mini series

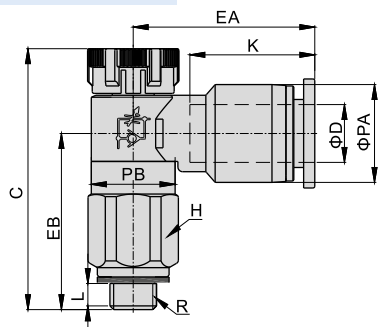

Model\Item [Note1]	ΦD	R	ΦPA	ΦPB	L	C		K	EA	EB	H	Weight (g)
						Pull	Push					
PTL4M5□-MS	4	M5×0.8	8.5	9	3.5	29.5	28	12.5	16.5	19	9	5
PTL401□-MS		1/8"	8.5	9	3.5	29.5	28	12.5	16.5	19	10	11
PTL6M5□-MS	6	M5×0.8	10.5	9	3.5	29.5	28	13.5	19.5	19	9	6.2
PTL601□-MS		1/8"	10.5	9	3.5	29.5	28	13.5	19.5	19	10	12

[Note1] "□" stands for A or B. A indicates meter-out type while B indicates meter-in type. The two types are with the same overall dimension.

Product feature

- Compare with standard speed controller, smaller size, lighter weight, suitable for more occasions.
- Effectively control the action speed and the pressure signal transmission from pneumatic device.
- Simple push-lock, operation.
- Adjust quickly, easily and accurately.
- Excellent flow rate characteristic, high sensitivity and easy to adjust.
- Options of Meter-out and meter-in, applicable for every type actuator.
- Effectively prevent from corrosion and pollution by nickel plated copper.
- The sealant being coated on threaded portion can ensure no leakage of the threaded connection part.

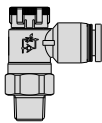
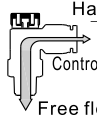

Table for interface port and tube O.D.

Product series	Thread type	Port size	
		Φ4	Φ6
PTL	M5	●	●
	1/8"	●	●

Ordering code

PTL 6 01 A □ □ - S

① ② ③ ④ ⑤ ⑥ ⑦

① Model	② Port size	③ Thread connection	④ Control method	⑤ Standard color	⑥ Thread type	⑦ Material
PTL: Speed controller (Push lock) 	6: Φ6mm	01: 1/8" 02: 1/4" 03: 3/8"	A: Meter-out  Handle marking "A" Controlled flow Free flow	Standard color	Blank: PT	S: SUS304
	8: Φ8mm	01: 1/8" 02: 1/4" 03: 3/8" 04: 1/2"		B: Meter-in  Handle marking "B" Free flow Controlled flow		
	10: Φ10mm	02: 1/4" 03: 3/8" 04: 1/2"	D: Black Release button: Black Body: Black			
	12: Φ12mm	03: 3/8" 04: 1/2"				

Specification

Operating pressure range	0~10kgf/cm²(0~1.0MPa)
Negative pressure	-750mmHg(10Torr)
Proof pressure	1.5MPa
Ambient and fluid temperature (°C)	-20~70
Applicable tubing	Soft nylon or polyurethane
Color	Grey/black

Product feature

1. Compare with standard speed controller, smaller size, lighter weight, suitable for more occasions.
2. Effectively control the action speed and the pressure signal transmission from pneumatic device.
3. Simple push-lock, operation.
4. Adjust quickly, easily and accurately.
5. Excellent flow rate characteristic, high sensitivity and easy to adjust.
6. Options of Meter-out and meter-in, applicable for every type actuator.
7. Effectively prevent from corrosion and pollution by nickel plated copper.
8. The sealant being coated on threaded portion can ensure no leakage of the threaded connection part.

Symbol

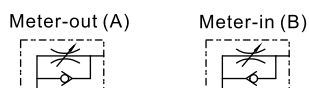

Table for interface port and tube O.D.

Product series	Thread type	Port size			
		Φ6	Φ8	Φ10	Φ12
PTL	1/8"	●	●		
	1/4"	●	●	●	
	3/8"	●	●	●	●
	1/2"		●	●	●

Selection, Installation and Operation

1. The rotation torque of the push-lock speed controller cap should not be too large to avoid damage. It is recommended to use the torque below.

Thread size	Recommended torque(N.m)
1/8"	0.08
1/4"	0.16
3/8"	0.24
1/2"	0.32

2. Push-lock speed controller installation instructions is the same as general one. Please refer to general type for specific content.

Inner structure

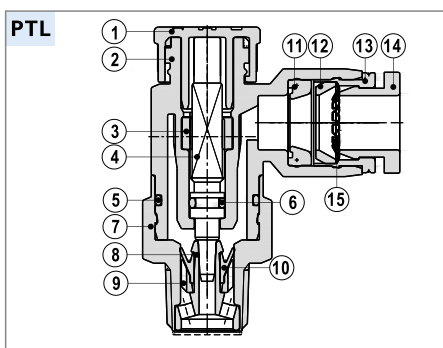

NO.	Name	Material	NO.	Name	Material
1	Adjusting cap	POM	9	Holder	PBT
2	Plastic body	PBT	10	O-ring	NBR
3	Locating ring	Aluminum alloy	11	O-ring	NBR
4	Throttling column	Aluminum alloy	12	Locating seat	POM
5	O-ring	NBR	13	Locating ring	Aluminum alloy
6	O-ring	NBR	14	Plastic interface	POM
7	Throttling body	SUS304	15	Spring gasket	Stainless steel
8	Throttling sleeve	Aluminum alloy			

Dimensions

PTL Series

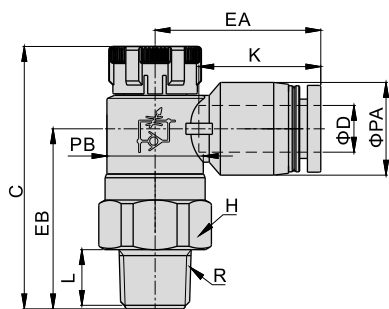

Model/Item [Note1]	ΦD	R	ΦPA	ΦPB	L	C		K	EA	EB	H	Weight (g)
						Pull	Push					
PTL601□-S	6	1/8"	12.5	13	8.5	36	34.5	16.5	22.5	23.5	14	12.5
PTL602□-S		1/4"	12.5	16.5	11	40.5	39	16.5	24	28	17	19.5
PTL603□-S		3/8"	12.5	19	12	44	42.5	16.5	25.5	31	19	28.5
PTL801□-S	8	1/8"	15	13	8.5	36	34.5	18.5	24.5	22.5	14	13
PTL802□-S		1/4"	15	16.5	11	40.5	39	18.5	26	27	17	20.5
PTL803□-S		3/8"	15	19	12	44	42.5	18.5	27	30	19	29
PTL804□-S	1/2"	15	24	15	52.5	51	18.5	29.5	37.5	24	49	
PTL1002□-S	10	1/4"	18	16.5	11	40.5	39	21	31	26	17	22
PTL1003□-S		3/8"	18	19	12	44	42.5	21	29	29	19	30.5
PTL1004□-S		1/2"	18	24	15	52.5	51	21	31.5	36.5	24	50.5
PTL1203□-S	12	3/8"	21	19	12	44	42.5	23	34.5	28	19	32.5
PTL1204□-S		1/2"	21	24	15	52.5	51	23	34	36	24	53

[Note1] "□" stands for A or B. A indicates meter-out type while B indicates meter-in type. The two types are with the same overall dimension.

Flowrate characteristic

Controlled flow rate

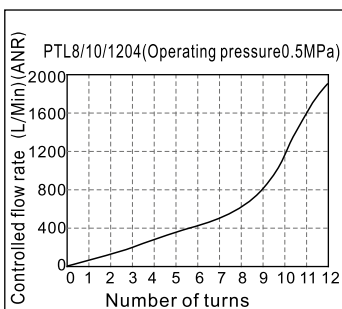
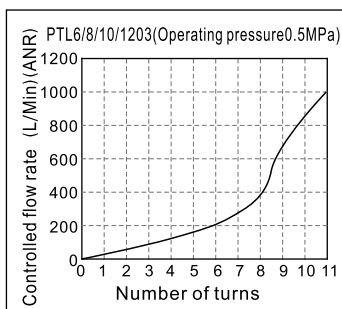
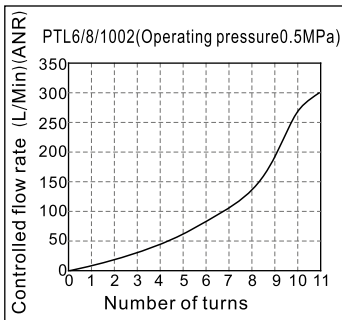
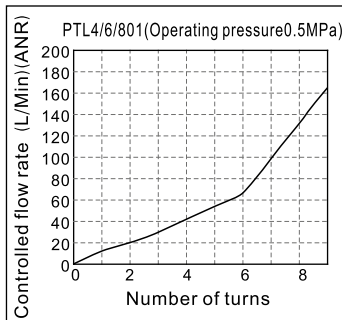
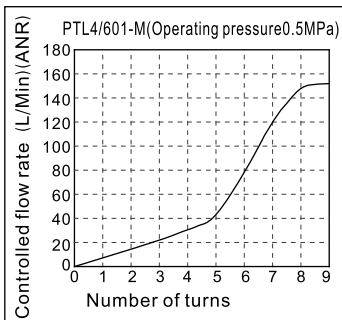
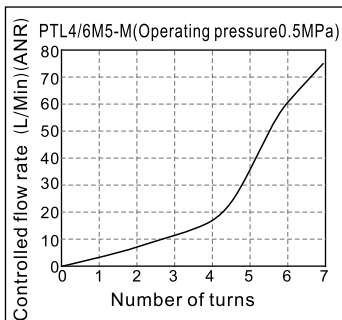

Free flow rate

